

**TECHNICAL MANUAL**

**OPERATOR'S, ORGANIZATIONAL, DIRECT SUPPORT,  
AND GENERAL SUPPORT MAINTENANCE MANUAL  
(INCLUDING REPAIR PARTS AND SPECIAL TOOLS LISTS)**

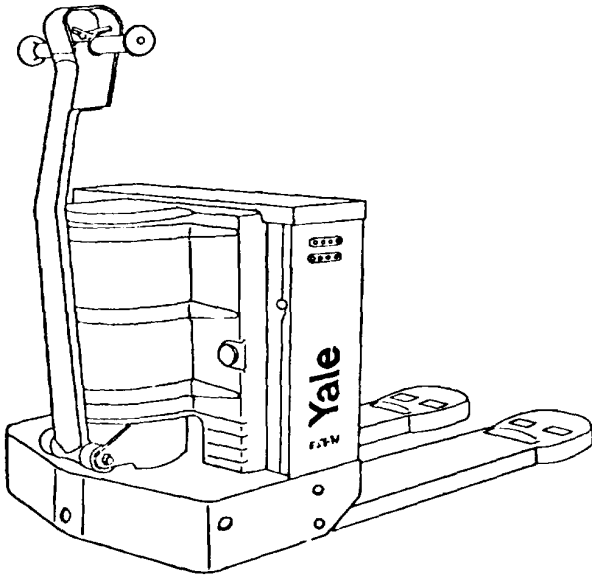

Operator's Instructions  
Page 5

Repair Parts  
Page 7

Service Instructions  
Page 35

SOMARPI  
Page 87

**TRUCK, PALLET-TYPE, 12-VOLT ELECTRIC-DRIVEN,  
SOLID RUBBER TIRES, 4,000-LB CAPACITY  
(YALE MODEL MP040C2M2742EE)  
NSN 3930-01-089-1429**

HEADQUARTERS, DEPARTMENT OF THE ARMY  
DECEMBER 1981

**WARNING**

The maximum capacity of this truck is 4,000 pounds (2 tons). Do not overload.

**WARNING**

**Fire Hazard**

Before operation, check to be sure all covers are in place and no thermostat is bypassed. Failure to observe this warning can result in ignition of explosives or flammable.

Check to be sure static electricity discharge straps are in good condition and dragging on the floor. Failure to observe this warning can result in electrical sparks which can ignite explosives or flammable.

Never use dry cleaning solvent near an open flame or excessive heat. Flash point of dry cleaning solvent is 138°F.

**WARNING**

**Electrical Shock Hazard**

When assembling the control handle switch, check to be sure you install the gasket between the cover and the housing.

**WARNING**

**Asbestos Hazard**

Always wear a protective mask or filter when disassembling drive unit. Asbestos dust from the brake linings may collect in the drive unit. Asbestos dust can cause lung damage.

**WARNING**

**Falling Equipment Hazard**

Never ride or carry passengers on this truck.

Never move unstable or loosely stacked loads.

The forks of this truck are not adjustable. Center pallet under the load before lifting.

Always start, stop, travel, steer, and brake smoothly.

Always travel with the load downhill.

Do not angle or turn on ramps.

Check all bridge plates to see that they are secure. Never exceed the rated capacity of bridge plates.

**WARNING**

Keep hands inside the handle guard. Keep feet clear of linkage at all times. Serious injury can result if you get caught in the linkage.

**WARNING**

Do not operate or maintain this truck unless you are trained and authorized to do so. Check your truck daily. If it needs repair, or is defective or unsafe in any way, do not use the truck. Failure to observe this warning can result in serious personal injury.

To shut down the truck:

- lower the forks
- leave controls in neutral
- set brakes
- remove the key.

If it is necessary to park on an incline, block the wheels firmly.

*This publication contains copyright material*

TECHNICAL MANUAL  
NO. 10-3930-648-14&P

HEADQUARTERS  
DEPARTMENT OF THE ARMY  
WASHINGTON, DC, 30 December 1981

OPERATOR'S, ORGANIZATIONAL, DIRECT SUPPORT,  
AND GENERAL SUPPORT MAINTENANCE MANUAL  
(INCLUDING REPAIR PARTS, AND SPECIAL TOOLS LISTS)  
FOR  
TRUCK, PALLET-TYPE, 12-VOLT ELECTRIC-DRIVEN,  
SOLID RUBBER TIRES, 4,000 LB CAPACITY  
(YALE MODEL MP040C2M2742EE)  
NSN 3930-01-089-1429

REPORTING OF ERRORS

You can improve this manual by recommending improvements using DA Form 2028 (Recommended Changes to Publications and Blank Forms) or DA Form 2028-2 located in the back of this manual. Mail the form direct to Commander, US Army Tank-Automotive Command, ATTN: DRSTA-MBS, Warren, MI 48090. A reply will be furnished direct to you.

			<i>Page</i>
PART ONE	Operator's Instructions .....		5
TWO	Repair Parts .....		7
THREE	Service Instructions.....		35
FOUR	SOMARPI .....		87

This technical manual is an authentication of the manufacturer's commercial literature and does not conform with the format and content specified in AR 310-3, Military Publications. This technical manual does, however, contain available information that is essential to the operation and maintenance of the equipment.

MFG. MODEL - MP040C2M2742 EE

NSN 3930 - 01 - 089 - 1429

NOMENCLATURE - TRUCK, PALLET, POWERED,  
ELECTRIC

CONTRACTOR -  
EATON CORP.- INDUSTRIAL TRUCK DIV.  
11000 ROOSEVELT BLVD.  
PHILA., PENNA. 19115

CONTRACT NO. - DAAE07-79-C-6017

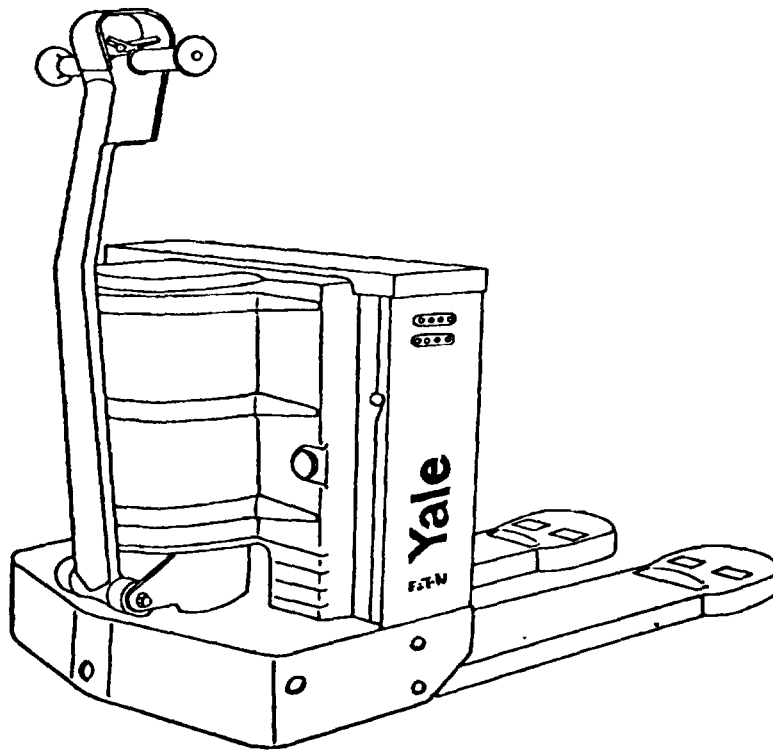

## Warranty

Eaton Corporation, Industrial Truck Division (ITD), warrants each new powered Yale industrial truck to be free of defective material or workmanship under proper use and service for one hundred eighty (180) days or one thousand (1000) hours of use, whichever first occurs, from date of delivery of the truck to the original user. During this warranty period, ITD will at its option repair or replace, free of charge, including material and labor, any item which in its sole opinion is determined to be defective. This warranty does not cover maintenance items, including but not limited to lubricating grease and oils, filters, fan belts, ignition parts, or minor adjustments, nor any items which show evidence of neglect, overload, abuse, accident, inadequate maintenance or unauthorized alteration. It is the user's responsibility to maintain the truck in accordance with ITD's recommended schedule of maintenance starting upon receipt of the truck. This warranty does not apply to other than Yale brand attachments. Such attachments are covered by the warranties, if any, of the manufacturers of those products.

In addition, coverage on all electric motors and drive train components (that is internal combustion engines, transmissions, drive axles, differentials, and SCR components), as well as Yale or ITD approved industrial battery chargers will be extended for parts only beyond the standard warranty, to a full year or two thousand (2000) hours of use, whichever first occurs, from date of delivery of the truck to the original user.

Yale or ITD approved industrial batteries will be warranted for a period of three (3) years from date of delivery to the original user.

For starting batteries and batteries used in internal power packs, adjustment will also be made after the standard warranty period on a basis of the number of months in use and the type of battery. Labor and freight are not covered after the standard warranty period.

This warranty may not be changed, altered or modified in any way except in writing by ITD. This warranty shall be void if repairs or alterations to a Yale industrial truck are made by any person or firm other than ITD or an ITD dealer so as in ITD's opinion to affect adversely in any way the stability or reliability of such truck.

ITD's obligation to repair or replace shall be the limit of its liability under this warranty and the sole and exclusive right and remedy of the user. Liability or obligation on the part of ITD for any other amount or damages is hereby disclaimed, whether incidental, consequential, general, special, in contract, tort, for negligence or otherwise. There are no warranties that extend beyond the description on the face hereof.

THIS WARRANTY IS EXPRESSLY IN LIEU OF ALL OTHER WARRANTIES, EXPRESS OR IMPLIED, WRITTEN OR ORAL, INCLUDING WITHOUT LIMITATION ANY IMPLIED WARRANTIES OF MERCHANTABILITY OR OF FITNESS FOR A PARTICULAR PURPOSE.

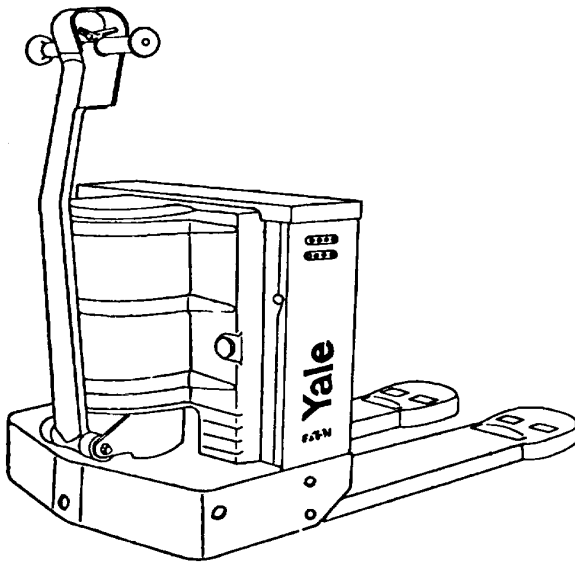
*The MP Story...features*

**Pallet Trucks...  
designed for  
durability and  
easy maintenance**

**POWERFUL DRIVE UNIT**

Smooth acceleration characteristics and maximum torque are provided by a totally enclosed drive unit having double reduction direct gear drive. All gears operate in an oil bath and all rotating parts are mounted on ball bearings assuring long life and quiet, trouble-free performance. Entire drive unit is mounted on a large-diameter ball bearing race that is designed to resist shock and distortion and provide easiest possible steering. Positive acting safety brake is external contracting shoe type, spring applied and cam released. Drum is mounted on first reduction shaft of drive unit.

Large, easily removed cover provides ready access to drive unit and electrical components for inspection and repair. Drive wheel is bolted on for easy removal.

**CONTACTOR DRIVE CONTROL**

Rugged, magnetic contactor control provides three speeds forward and reverse.

**--- handle design  
makes operation easy,  
fast and safe**

Operator can lift or lower while maneuvering, has complete control of truck at all times.

**EASY STEERING**

Large handle grips and wide 200° steering arc make close quarter operation and right angle turns an easy matter. Drive unit is ball bearing mounted for minimum steering effort.

**POSITIVE BRAKING**

Raising or lowering the steering handle all the way applies the brake and cuts off power. The handle automatically returns to vertical when released.

**PRECISE TRAVEL CONTROL**

A rugged, maintenance-free butterfly switch at the top of the steering handle controls forward or reverse speed in response to thumb pressure from either hand. A safety guard protects the switch against impact.

**PUSHBUTTON LIFT AND LOWER**

Fingertip control of lifting or lowering while maneuvering means top working efficiency

**12-VOLT POWER —**

**QUICK, EASY BATTERY REMOVAL**

Pallet trucks accommodate a wide range of 12-volt industrial batteries to match any kind of duty cycle.

The hinged battery cover swings up out of the way for quick, easy servicing. Hinged cover and lift-off side plates simplify top or side battery removal.

**RUGGED, COMPACT FRAME . . . PROTECTED,  
ACCESSIBLE LIFTING COMPONENTS**

The rugged, steel frame is electrically welded into a unit structure for strength and rigidity. Its compact design protects hydraulic components and lifting linkage, yet provides ready access for maintenance.

The large capacity hydraulic reservoir and motor-driven pump are highly efficient. Lifting linkage is easily adjusted and lubricated. The reservoir breather cap extends through the floor plate for quick servicing. Load wheels are also easily lubricated without lifting the truck.

**HIGH UNDERCLEARANCE —  
CLEAN DESIGN**

Because nothing protrudes below the frame, under clearance is high and dock board hang up minimized. Pallet forks are protected to prevent foreign objects from becoming entangled in tension rods.

INDEX

AXLE, Drive .....	14	TERMINAL BLOCKS .....	9
AXLE, Load .....	32	TIRE, Drive .....	14
BRAKE DRUM .....	17	TORQUE VALUES .....	43
BRAKE SHOES and Linkage .....	17	TRAY, Battery .....	8
CONTACTOR Assembly .....	20	VALVE, Solenoid Release .....	28
CONTACTOR, Hoist .....	9	VENDOR CROSS REFERENCE.....	41-42
CONTACTOR, Reversing .....	22	WHEEL, Drive .....	14
COVER, Battery .....	8	WHEEL, Load .....	32
COVER, Drive Unit.....	8	WIRING DIAGRAM.....	34
CYLINDER, Lift .....	29	WIRE HARNESS, Contactors.....	20
Diode .....	9	WIRE HARNESS, Control Handle .....	10
Drive Unit.....	14	WIRE HARNESS, Drive Motor.....	20
ELECTRICAL ACCESSORIES .....	9		
FUSE, Horn .....	20		
FUSE, Power.....	9		
GENERAL TRUCK .....	8		
HANDLE, Control .....	10		
HORN.....	9		
HOUSING, Drive Unit.....	10'		
HYDRAULIC DIAGRAM .....	33		
LINKAGE, Lift .....	30		
LUBRICATION CHART .....	36		
MAINTENANCE .....	46		
MOTOR, Drive Unit .....	18		
MOTOR, Hydraulic Pump.....	25		
OPERATORS INSTRUCTIONS.....	5		
OPERATORS WARNINGS .....	6		
PALLET FORKS.....	30		
PLATES, Battery Side .....	8		
PAN, Splash .....	24		
PUMP, Hydraulic .....	26		
PUMP and Motor .....	24		
PULL RODS .....	30		
RECEPTACLE, Battery .....	34		
RECOMMENDED SERVICE CHECKS.....	35		
RESISTOR, Drive.....	20		
SERVICE INSTRUCTIONS.....	44		
SWITCH, Cutout, .....	9		
SWITCH, Hydraulic Pressure .....	33		
SWITCH, Control .....	12		

## MAINTENANCE INDEX

Battery .....	86
Control Handle .....	69
Switch .....	71
Torsion Springs.....	69
Drive Unit .....	57
Brake Shoes	
Remove .....	58
Install .....	62
Adjust .....	62
Drive Motor	
Remove .....	58
Install .....	61
Disassemble .....	67
Drive Wheel .....	57
Gear Adjustment.....	64
Ring Bearing	
Remove .....	59
Install .....	59
Adjust .....	62
<b>ELECTRICAL SYSTEM</b> .....	46
Contactor Assembly.....	46
Cutout Relay .....	49
Cutout Switch .....	62
Fwd. & Rev. Contactor.....	46
Hoist Contactor .....	49
2nd & 3rd Speed Contactor .....	49
Power Fuses .....	49
Resistor .....	49
Troubleshooting .....	52
Wiring Diagram .....	54
<b>HYDRAULIC SYSTEM</b> .....	76
Hydraulic Pump .....	78
Lift Cylinder .....	80
Pump Motor .....	77
Pump and Motor .....	76
Troubleshooting .....	82
<b>PALLET &amp; LIFT LINKAGE</b> .....	73
Load Wheel	
Disassemble.....	73
Reassemble .....	74
Pallet	
Remove .....	73
Disassemble.....	73
Reassemble .....	74
Adjust .....	75
<b>SERVICE HINTS</b> .....	44





OPERATORS INSTRUCTIONS

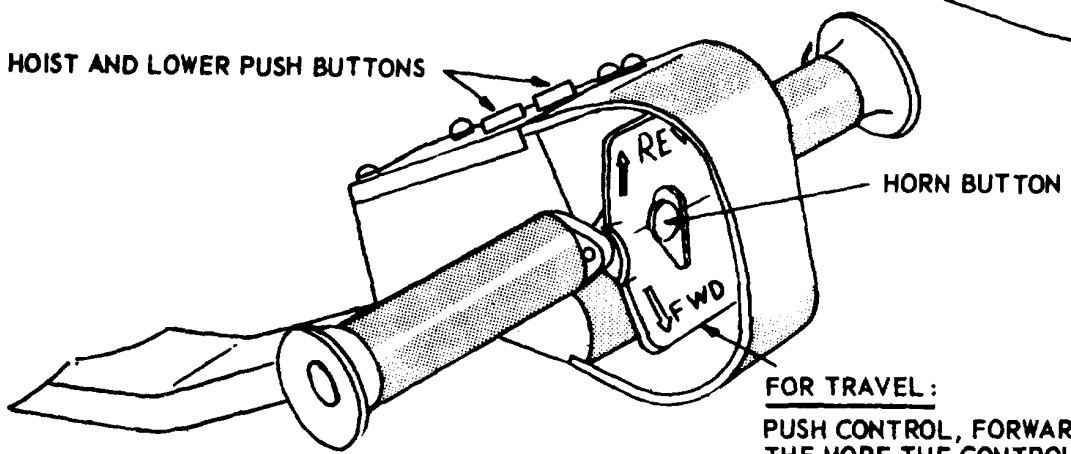
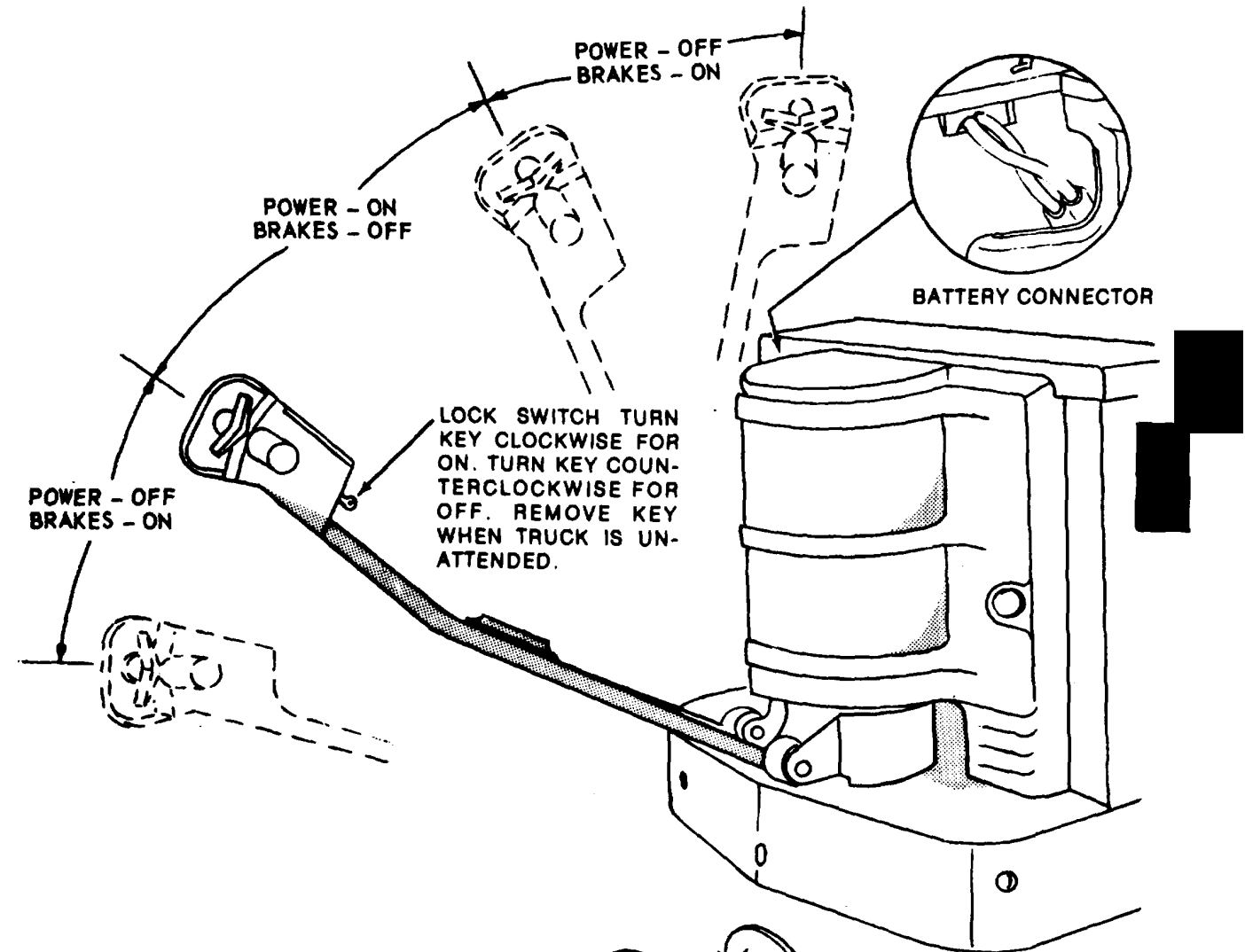

**WARNING to the operator —  
for your safety and the safety of others**



1. **KNOW YOUR TRUCK** - Do not operate or maintain this truck unless you have been trained and authorized to do so.
2. **CHECK YOUR TRUCK** - Truck should be checked daily before being placed in service. Refer to page 35 for safety and maintenance checklist. If truck is found to be in need of repair, defective, or in any way unsafe, it should be reported immediately to the proper authority and the truck removed from service until it has been restored to a safe operating condition.
3. **NO RIDERS** - Do not ride or carry passengers on this truck.
4. **STAND CLEAR** - Stay at arms length from control handle, keep hands within handle guard and feet clear of truck. Never place any part of your body in the linkage.
5. **STABILIZE YOUR LOAD** - Do not handle unstable or loosely stacked loads. Use special care when handling long, high or wide loads to avoid losing the load, striking bystanders, or tipping the truck.
6. **CENTER YOUR LOAD** - Center the pallets under the load before lifting the load.
7. **NEVER OVERLOAD** - Do not overload the truck. The maximum capacity of this truck is 4,000 pounds.
8. **AVOID SUDDEN MOVEMENT** - Start, stop, travel, steer and brake smoothly. Use special care when traveling without a load as the risk of overturning the truck is greater.
9. **CARE ON RAMPS** - Use special care when operating on ramps, travel slowly, and do not angle or turn. Always travel with load or lifting mechanism downhill.
10. **SECURE BRIDGEPLATES** - Drive carefully and slowly across dock boards or bridge plates. Never exceed their rated capacity. Be sure they are properly secured.
11. **SHUT DOWN COMPLETELY** - When leaving truck unattended, lower lifting mechanism, controls in neutral, brakes set, switch off and key removed, battery disconnected. If necessary to park on an incline, the wheels must be firmly blocked.
12. **WARNING** - This truck has been built with UL classified "EE" construction which means that all electric motors and all electrical components have been enclosed with sealed covers and protected from overheating by thermostats which will interrupt power to the overheated component. Under no circumstances should this truck be operated with any cover removed or a thermostat bypassed. Failure to comply with this warning could result in ignition of explosive or flammable.
13. **WARNING** - Insure that static electrical discharge straps are installed on truck and in good condition (dragging on floor). Failure to use straps could result in the generation of sparks, which could cause ignition of explosives or flammable.

**Failure to comply with these warnings will create an unreasonable risk of injury to yourself and others.**

## ORDERING OF PARTS

In order to avoid delay, unnecessary correspondence, and to have your orders filled correctly, and at the least possible expense, the following is the recommended procedure to use when ordering replacement parts.

### WHEN ORDERING PARTS

Call, wire, or write to your authorized YALE Representative giving him the following information:

1. Your Purchase Order Numbers.
2. Complete Invoicing and Shipping Address.
3. Specify Method of Shipment.  
(Otherwise least expensive method will be used).
4. Correct Part Number(s) and Description(s).  
(Use your Parts Manual as reference.)
5. Model and Serial Number of Truck which are stamped into the Capacity Plate located as shown below.

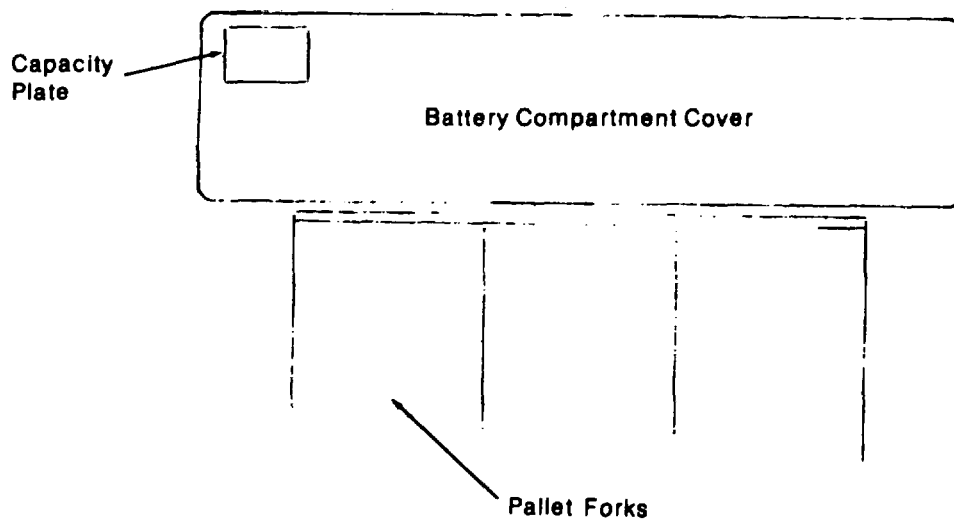

This truck is equipped with the following battery.

Make - Yale  
 Model - 6-85Y-13  
 Voltage - 12 Volts  
 Amp. Hour - 510  
 Amp. Hour Capacity - 6 Hr. Rate  
 Weight - 477 Lbs.  
 Size - 30.75" L. x 7.88" W. x 22.6" H.

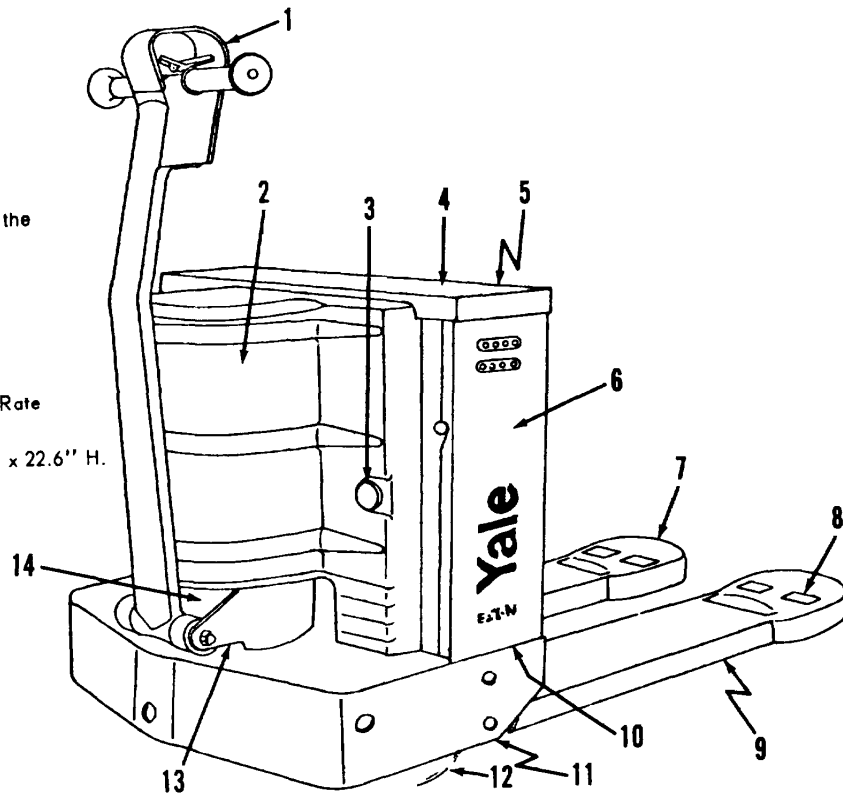

**GENERAL TRUCK - MP040C2M2742EE**

ITEM	PART NO.	DESCRIPTION	NO. REQD.
1	7219760-18	Control Handle - (Refer to Page 10) .....	1
2	7210926-03	Drive Unit Cover .....	1
	6202891-04	Rubber Channel Gasket .....	1
3	7215281-00	Knob .....	1
4	5011774-00	Cover .....	1
	7201701-02	Lock Clip - (Order W/Cover) .....	1
	7201701-03	Lock Clip-- (Order W/Cover) .....	1
5	Commercial	Pad Lock .....	1
6	7224174-01	L.H. Side Plate - (Shown) .....	1
7	7224174-02	R.H. Side Plate - (Opposite) .....	1
7	7220906-33	9" Pallet Fork Weldment - 27" Wide X 42" Long .....	1
8	7215090-01	Poly Load Wheel Group - (Refer to Page 32).....	2
9		Pallet and Lift Linkage - (Refer to Page 30).....	
10	7221543-00	Battery Tray .....	1
	7226173-01	Battery Retainer .....	2
11	7225514-00	Pump, Motor and Release Valve - (Refer to Page 24) .....	1
12	0310585-00	Static Strap .....	2
13	5017894-00	Housing.....	1
14	7204420-75	Drive Unit Assembly - (Refer to Page 14).....	1
	0576997-00	Hex Screw .....	2
	7201969-05	Flat Head Socket Screw .....	2
	0150011-00	Locknut .....	4

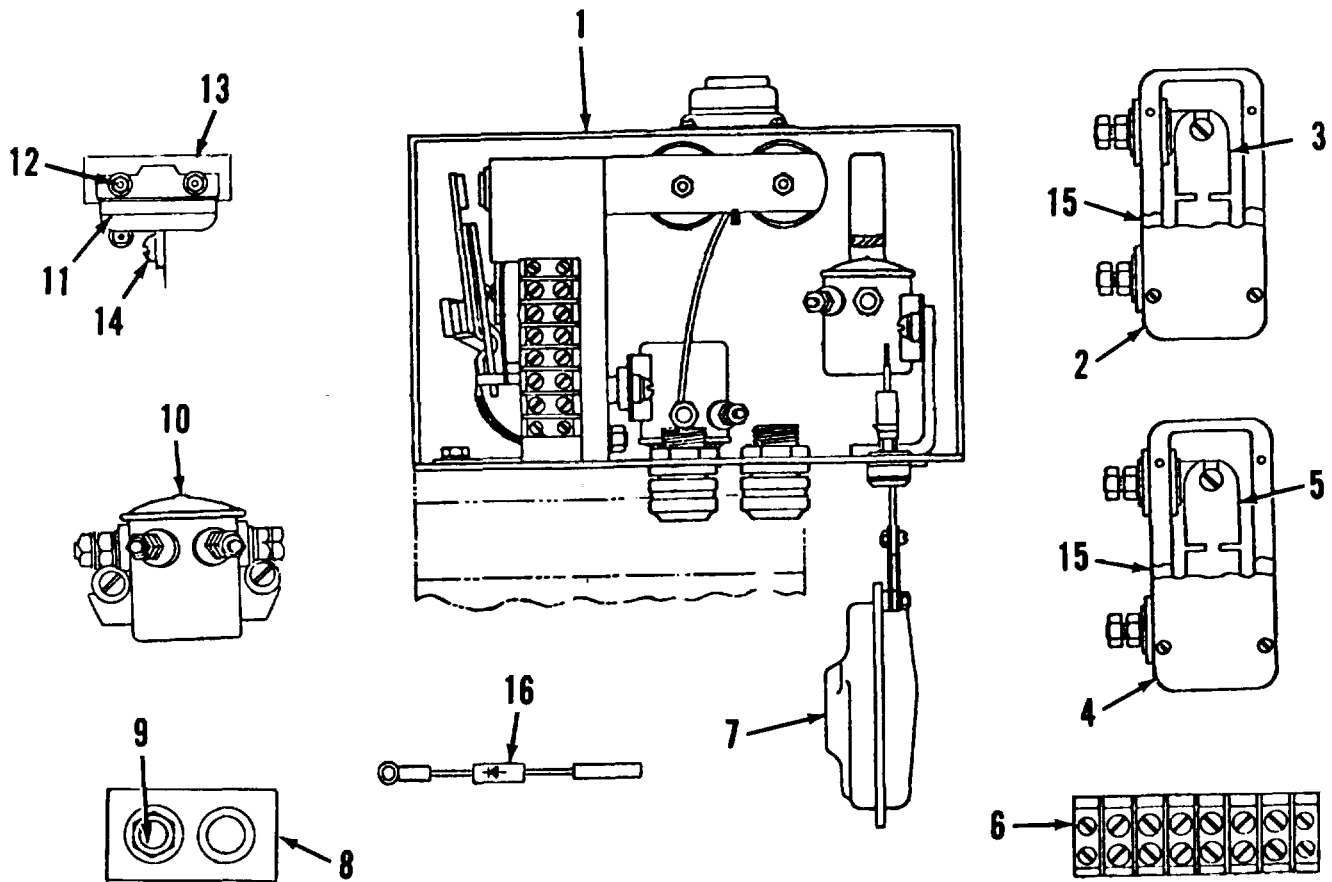

**ELECTRICAL ACCESSORIES**

ITEM	PART NO.	DESCRIPTION	NO. REQD.
1	7214140-21	Contactor Assembly (Refer to Page 20).....	1
2	7207120-02	Fuse Box Assembly - Less Fuse (See Note).....	1
3	1067861-27	200 Amp Fuse-- For Lift Circuit .....	1
4	7207120-08	Fuse Box Assembly - Less Fuse (See Note) .....	1
5	1067861-31	100Amp Fuse-- For Drive Circuit .....	1
6	5016443-03	Terminal Block (See Note) .....	1
7	7235184-00	12 Volt Horn .....	1
8	7201281-00	Terminal Block (For Drive Motor Wires) (See Note) .....	1
9	Commercial	3/8" - 16 X 1-1/4" Lg. Brass Rd. Hd. Screw .....	1
	Commercial	3/8" - 16 Brass Hex Nut .....	1
10	5012703-04	12 Volt Lift Contactor (See Note) .....	1
11	5152921-00	Cutout Switch (Mounted on Drive Unit Housing) .....	1
12	Commercial	6-32 X 1" Lg. Rd. Hd. Screw - Cadmium Plated .....	2
	Commercial	6-32 Hex Nut - Cadmium Plated.....	2
	Commercial	6 Lockwasher-- Cadmium Plated .....	2
13	7233533-00	Bracket.....	1
14	Commercial	1/4" - 20 X 3/4" Lg. Rd. Hd. Screw .....	2
	Commercial	1/4" Shakeproof Lockwasher .....	2
15	6083341-00	Gasket .....	2
16	7237211-00	Diode - For Cutout Relay.....	1

**NOTE:** Items 2, 4, 6, 8, 10 are mounted on the battery compartment under the drive unit cover.

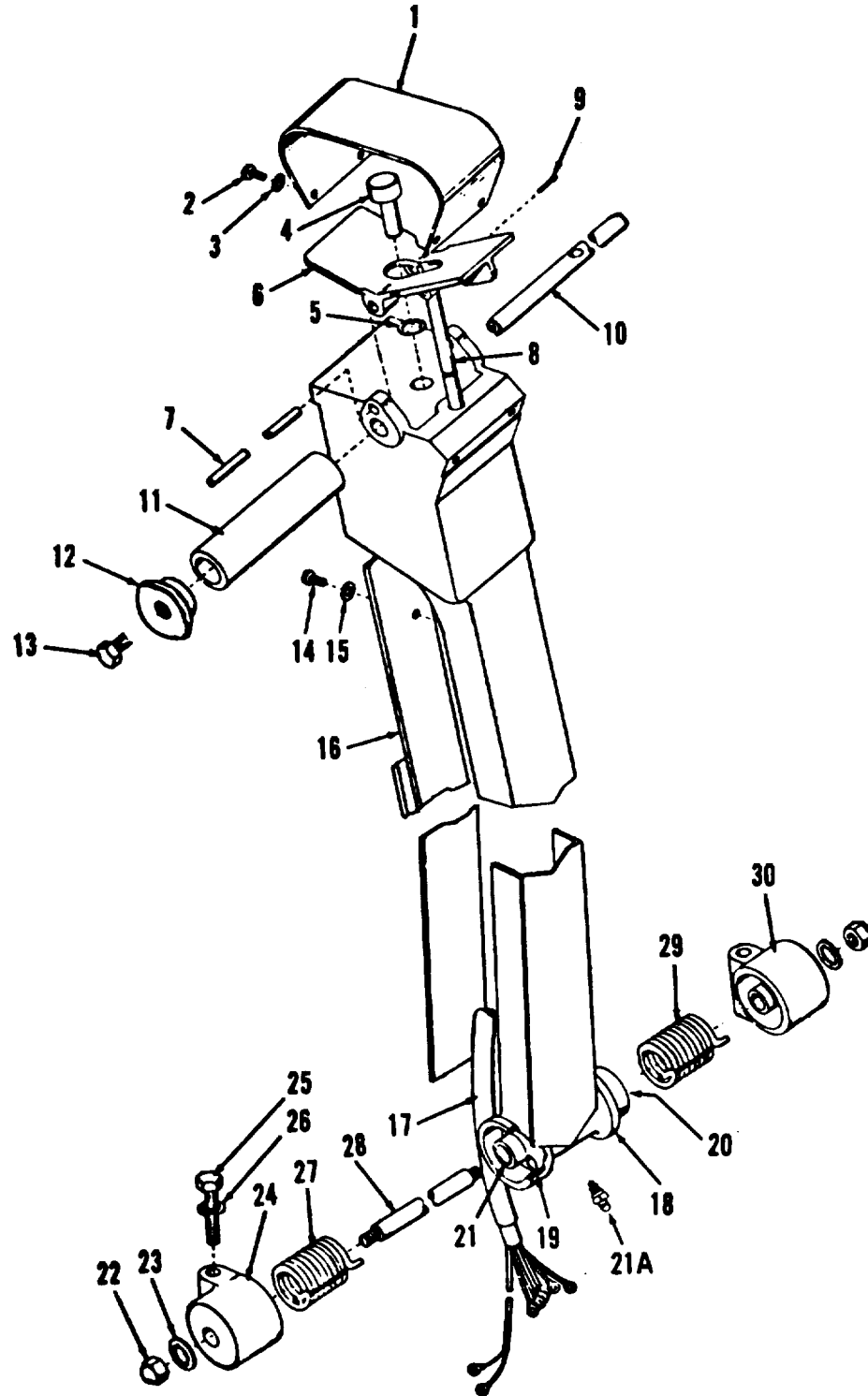

7219760-18 CONTROL HANDLE - RESISTOR - "EE"

**CONTROL HANDLE - RESISTOR - "EE"**

ITEM	PART NO.	DESCRIPTION	NO. REQD.
1	6200881-00	Guard.....	1
2	Commercial	1/4" - 20 X 5/8" Lg. Rd. Hd. Screw .....	4
3	Commercial	1/4" Lockwasher .....	4
4	7235491-00	Horn Button.....	1
5	0597130-00	Retaining Ring .....	1
6	6200313-00	Travel Control Plate .....	1
7	7200389-02	1/4" Dia. X 1" Lg. Roll Pin .....	2
8	7224211-00	Control Rod.....	1
	6202841-00	Rod End.....	1
	0655021-00	1/8" Dia. X 3/8" Lg. Drive-Loc Pin .....	1
9	Commercial	1/8" Dia. X 2" Lg. Cotter Pin .....	1
10	7237183-00	Handle Bar.....	1
11	6200861-00	Grip .....	2
12	7237213-00	Knob .....	2
13	7203329-06	3/8" - 16 X 1-1/4" Lg. Self-Locking Screw.....	2
14	Commercial	1/4" - 20 X 1/2" Lg. Rd. Hd. Screw .....	3
15	Commercial	1/4" Flat Washer .....	3
16	7238053-00	Cover W/Rubber Bumper .....	1
17	7236356-00	Wire Harness .....	1
18	7240413-02	Handle - Includes Items 19, 20 & 21 (Following Items Not Included	
	W/Handle .....		1
	7200389-03	7/16" Dia. X1" Lg. Drive-Loc Pin .....	1
	7239783-00	Wire Guard .....	1
19	6201211-00	Insert.....	1
20	7236991-00	Insert.....	1
21	5005969-24	Bushing.....	2
21A	0227845-00	Lube Fitting.....	1

**FOLLOWING ITEMS MUST BE ORDERED SEPARATELY.**

22	3117250-46	1/2" - 20 Cap Nut - Cadmium Plated .....	2
23	Commercial	1/2" Shakeproof Lockwasher .....	2
24	6200303-00	Support .....	1
25	3113033-58	5/8" - 11 X 3-1/2" Lg. Hex Hd. Screw - Gd. 5 Cadmium Plated - Torque 110-120 ft. lbs .....	2
26	Commercial	5/8" Lockwasher .....	2
27	7201541-00	Torsion Spring .....	1
28	6201231-00	Pivot Shaft - .....	1
29	7239413-00	Torsion Spring .....	1
30	7239903-00	Support .....	1

**NOTE:** All Commercial Hardware Cadmium Plated.

Continued



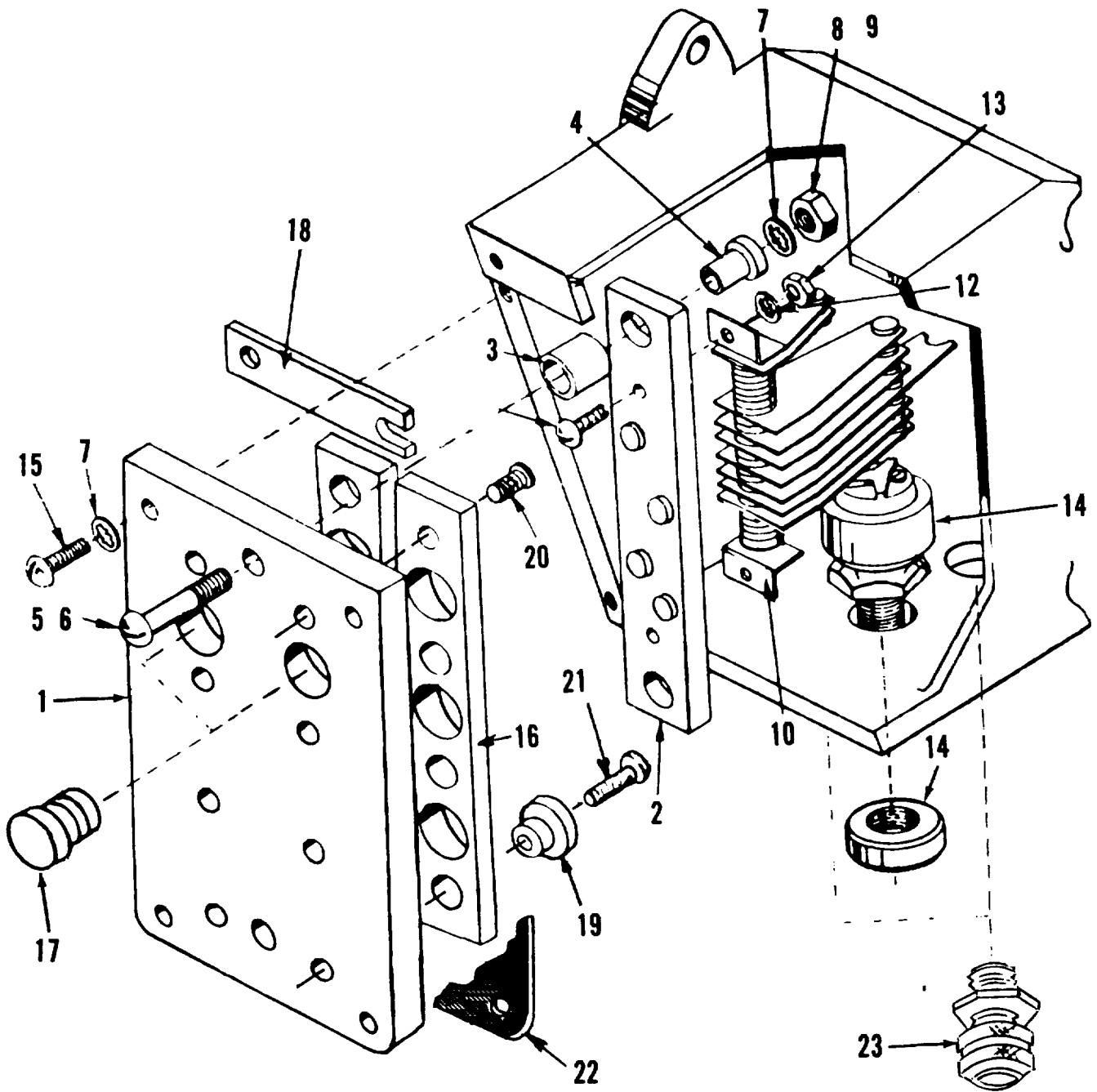

7219760-18 CONTROL HANDLE - RESISTOR - "EE"

**CONTROL HANDLE - RESISTOR - "EE"**

ITEM	PART NO.	DESCRIPTION	NO. REQD.
1	6201293-0F	Plate.....	1
2	6200791-00	Bar .....	1
3	6200801-00	Spacer .....	2
4	6200781-00	Bushing.....	2
5	Commercial	1/4" - 20 X 1-1/2" Lg. Rd. Hd. Screw .....	1
6	Commercial	1/4" - 20X 1-5/8" Lg. Rd. Hd. Screw.....	1
7	Commercial	11/4" Shakeproof Lockwasher.....	6
8	Commercial	1/4" - 20 Hex Nut .....	1
9	Commercial	1/4" - 20 Hex Jam Nut .....	1
10	7221523-00	Switch Assembly.....	1
11	Commercial	#5-40 X 1/2" Lg. Rd. Hd. Screw .....	2
12	Commercial	#5 Shakeproof Lockwasher .....	6
13	Commercial	#5-40 Hex Nut .....	2
14	5008631-00	Lock Switch W/Keys .....	1
15	Commercial	1/4" - 20 X 5/8" Lg. Hex Screw .....	4
16	6200771-00	Insulator Strip .....	2
17	6202821-00	Button .....	2
18	6200761-00	Switch Blade .....	2
19	6200811-00	Insulator .....	4
20	Commercial	#5-40 X 3/4" Lg. Rd. Hd. Screw .....	2
21	Commercial	#5-50 X 3/8" Lg. Rd. Hd. Screw .....	2
22	6202831-00	Gasket - (Sparkproof) .....	1
23	6202941-0G	Sparkproof Connector .....	2
	6202941-0C	Rubber Grommet .....	2
	0103737-00	3/8" Electrical Conduit Nut.....	2

**NOTE:** All Commercial Hardware Cadmium Plated.

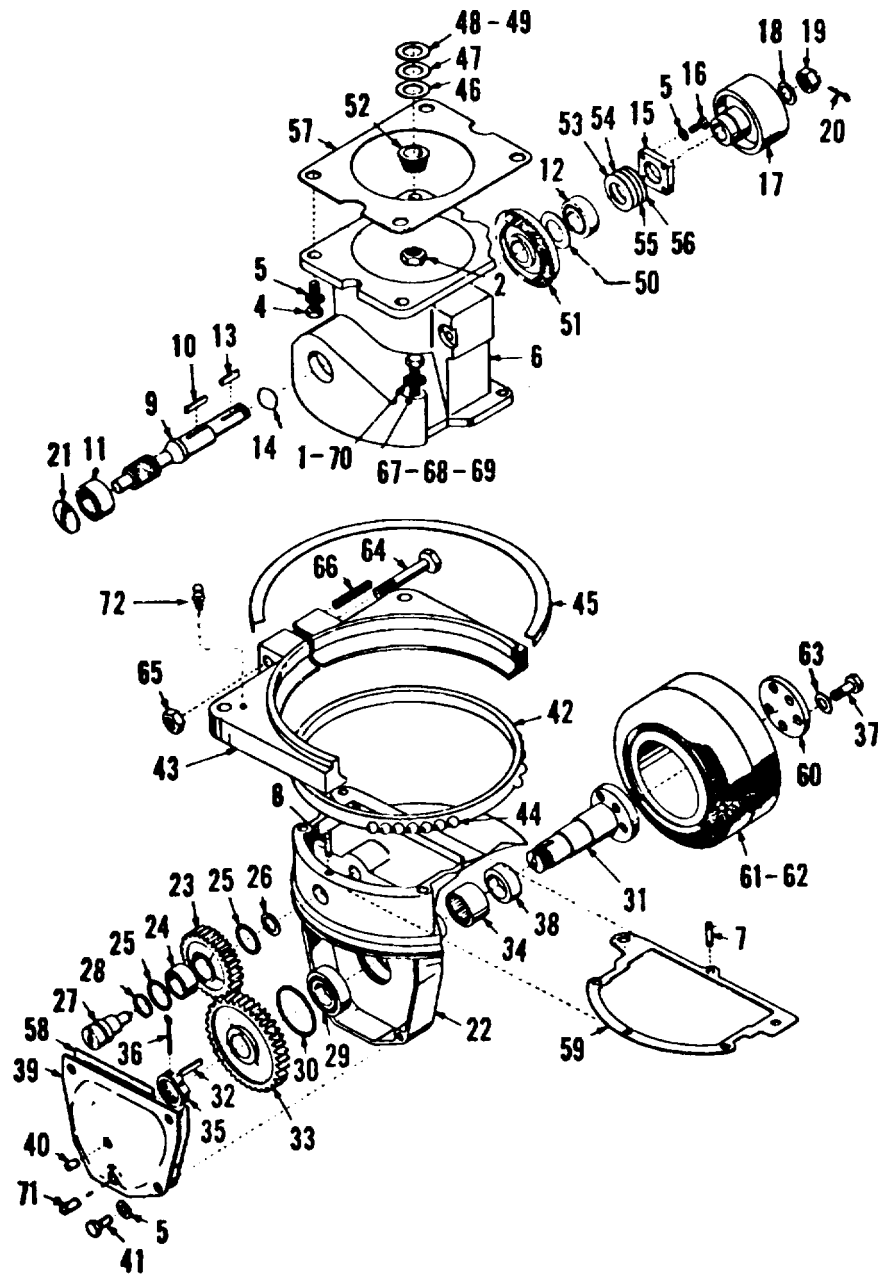

7204420-75 DRIVE UNIT ASSEMBLY - 12 VOLT - EE

DRIVE UNIT ASSEMBLY

ITEM	PART NO.	DESCRIPTION	NO. REQD.
1	Commercial	1/2" Lockwasher .....	3
2**	Commercial	1/2" - 20 Elastic Stop Nut.....	1
3		Not Used	
4	Commercial	3/8" - 16X 1" Lg. Hex Screw .....	4
5	Commercial	3/8" Lockwasher .....	4
6	6200017-00	Upper Housing .....	1
7*	5001399-01	Dowel Pin.....	1
8*	5001399-02	Dowel Pin.....	1
9	6200044-01	Shaft .....	1
10	5021729-04	Key.....	1
11*	5029288-00	Ball Bearing.....	1
12*	0151208-00	Bearing .....	1
13	5001479-02	Key.....	1
14*	5018029-01	"O" Ring .....	1
15	5015785-00	Bearing Retainer.....	1
16	0597115-00	3/8" - 16 X 3/4" Lg. Hex Screw --Gd. 5.....	4
17	6200033-00	Brake Drum .....	1
18	1300601-00	Washer .....	1
19	Commercial	5/8" - 18Castle Nut.....	1
20	Commercial	1/8" Dia. X 1" Lg. Cotter Pin.....	1
21*	5182168-00	Expansion Plug.....	1
22	6200087-00	Housing.....	1
23	6200093-00	Idler Gear.....	1
24*	0567048-00	Ball Bearing .....	1
25	6400469-20	Retaining Ring .....	2
26*	6200111-00	Spacer .....	1
27	6200073-00	Idler Gear Shaft .....	1
28*	0128288-00	"O" Ring.....	1
29*	5030118-00	Ball Bearing.....	1
30	5019899-03	Retaining Ring .....	1
31	7201483-00	Drive Axle Shaft.....	1
32*	7206971-00	Key.....	1
33	6200054-00	2nd Reduction Gear.....	1
34*	0270788-00	Roller Bearing .....	1
35	0880391-00	Nut .....	1
36	Commercial	1/8" Dia. X 3" Lg. Cotter Pin.....	1
37**	1298781-00	Bolt - Torque 140-160 ft. lbs. Dry.....	5
38*	7200049-03	Oil Seal .....	1
39	6200034-00	Cover .....	1
40	Commercial	1/4" Pipe Plug.....	1
41	Commercial	3/8" - 16 X 1-1/8" Lg. Hex Screw .....	4
42	6203984-00	Inner Race .....	1
43	6205536-00	Outer Race .....	1
44	7200609-01	Steel Ball- 1/2" Dia.....	72
45	6200153-00	Shield.....	1
46	6200333-0D	Shim - .007 .....	6
47	6200333-0R	Shim - .002" .....	2
48	6200333-0S	Shim - .003" .....	2
49	6200333-0U	Shim - .030" .....	1
50	6200333-0F	Shim - .005" .....	6
	6200333-0Q	Shim - .003" .....	4
51	7205621-00	Gear and Pinion Set - 22.5:1 Ratio.....	1
52		Order Item 51	

Continued

**DRIVE UNIT ASSEMBLY - CONTINUED**

ITEM	PART NO.	DESCRIPTION	NO. REQD.
53	6200783-0A	Shim - .004" .....	2
54	6200783-0B	Shim - .005 " .....	2
55	6200783-0C	Shim - .006" .....	2
56	6200783-0D	Shim - .007" .....	2
57*	6200934-0A	Gasket .....	1
58*	6200934-0B	Gasket .....	1
59*	6200934-0C	Gasket .....	1
60**	1292541-00	Clamp Plate .....	1
61**	5005329-05	10" Dia. X 5" Flat Smooth Rubber Tire .....	1
62**	1291143-00	Wheel .....	1
63**	0612783-00	Hardened Washer .....	5
64	0146623-00	5/8" - 18 X 4" Lg. Hex Bolt .....	1
65	0150038-00	5/8" - 18 Elastic Stop Nut.....	1
66	0209262-00	Setscrew .....	1
67	0607332-00	Hex Screw .....	2
68	0576997-00	Hex Screw .....	1
69	0655796-00	3/8" - 16 X 1" Lg. Socket Hd. Screw .....	1
70	0656194-00	3/8" Shakeproof Lockwasher .....	1
71*	0230828-00	1/4" Magnetic Pipe Plug.....	1
72	0156287-00	1/4" - 28 Straight Lube Fitting.....	2

**FOLLOWING ITEMS NOT SHOWN, BUT ARE INCLUDED WITH DRIVE UNITS.**

7220450-12	Drive Motor - 12 Volt (Refer to page 18) .....	1
------------	--	---

**FOLLOWING ITEM MUST BE ORDERED SEPARATELY.**

5189860-01	Drive Unit Gear Box Repair Kit - Includes * Items .....	1
------------	---	---

**NOTE:** \*\*Items Not Included With Drive Units.  
Must be Ordered Separately.

**NOTE:** All Commercial Hardware Cadmium Plated.

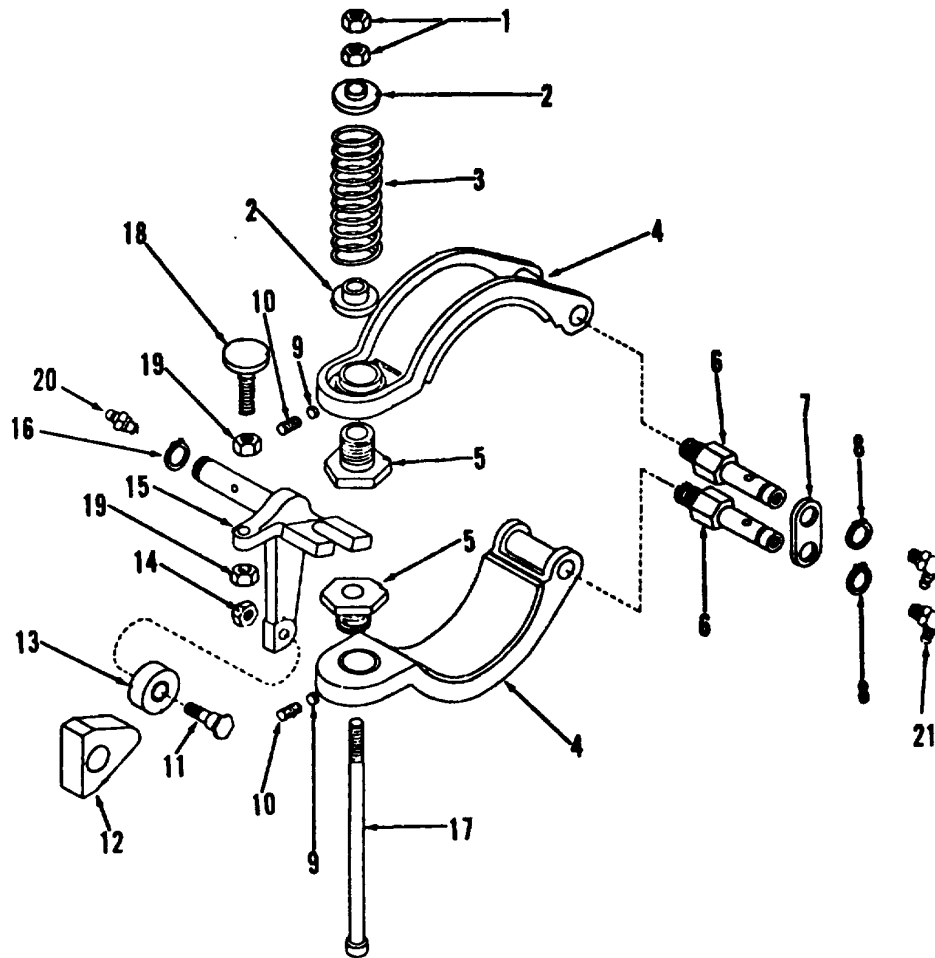

**BRAKE SHOES & LINKAGE**

ITEM	PART NO.	DESCRIPTION	NO. REQD.
1	Commercial	3/8" - 16 Hex Nut .....	2
2	6200051-00	Spring Seat .....	2
3	6200061-00	Spring .....	1
4	1315453-00	Brake Shoe W/Bonded Lining .....	2
5	7223161-00	Adjusting Screw .....	2
6	1302071-00	Pivot Pin.....	2
7	6200031-00	Link .....	1
8	0159182-00	Retaining Ring .....	2
9	6200431-00	Set Screw Seat.....	2
10	0148036-00	1/4" - 20 X 3/8" Lg. Set Screw (Cup) .....	2
11	6200071-00	Stud .....	1
12	7236701-00	Brake Cam.....	1
13	6200081-00	Roller W/Bushing .....	1
14	7200009-02	5/16" - 18 Elastic Stop Nut Heavy - Thin .....	1
15	6200014-00	Brake Release Arm .....	1
16	0159149-00	Retaining Ring .....	1
17	7223171-00	Rod .....	17
18	1303351-00	Switch Actuator.....	1
19	Commercial	1/4" - 20 Hex Nut Cad. Plate.....	1
20	0156287-00	1/4" - 28 Straight Lube Fitting .....	1
21	0156313-00	1/4" - 28 90° Lube Fitting .....	2

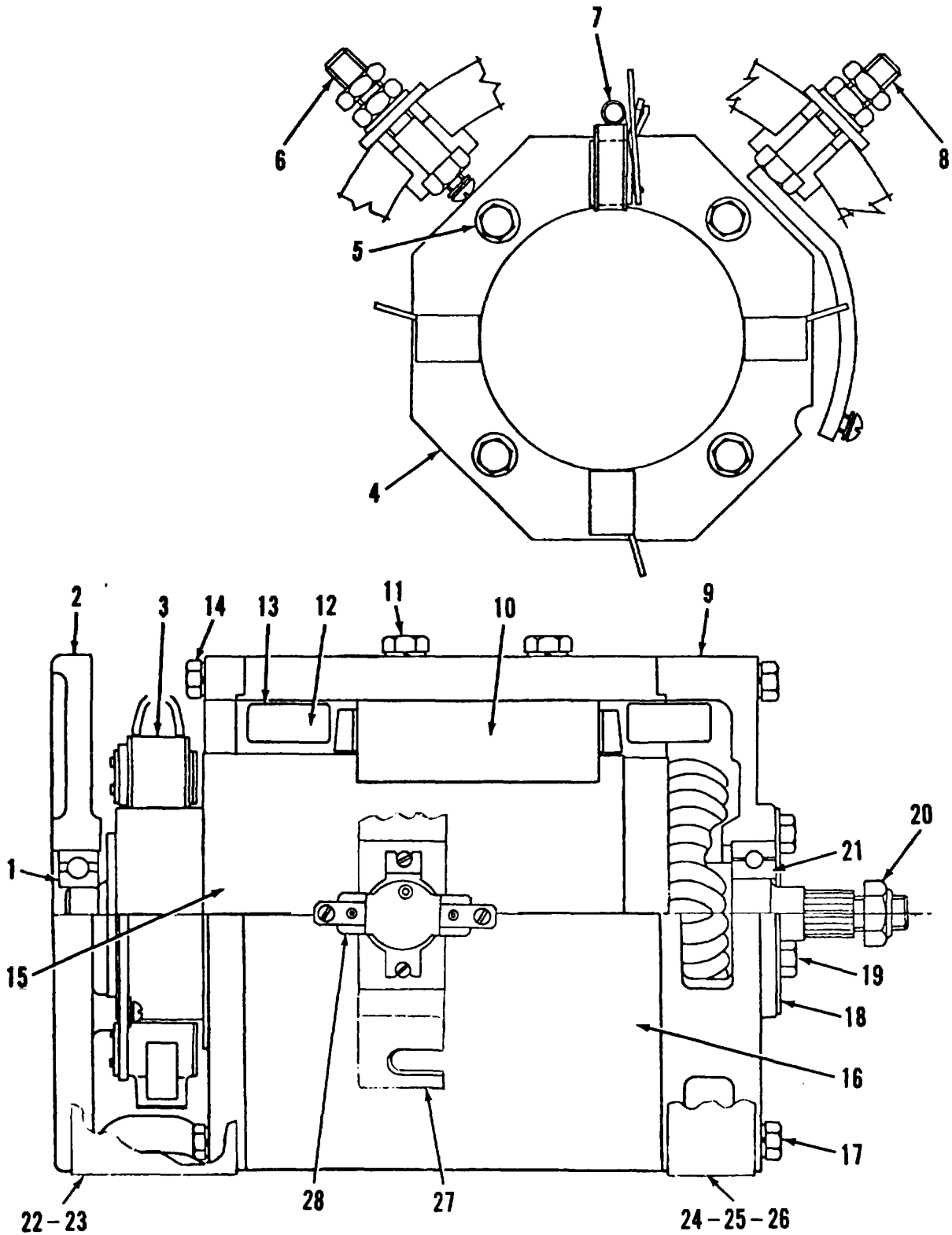

7220450-12 DRIVE MOTOR - 12 VOLT - W/ENCLOSED COVERS

**DRIVE MOTOR**

ITEM	PART NO.	DESCRIPTION	NO. REQD.
1	0805411-0M	Bearing .....	1
2	7210034-01	Commutator End Head W/Roll Pin .....	1
	Commercial	1/4" Dia. X 1" Lg. Roll Pin .....	1
3	1356501-16	Brush Set .....	1
4	7238643-00	Brush Holder Assembly -Only .....	1
5	Commercial	1/4" - 20 X 3/4" Lg Hex Screw - Cadmium Plate .....	4
	Commercial	1/4" Flat Washer .....	4
	Commercial	1/4" Lockwasher .....	4
6	5194680-15	Terminal Screw Package.....	2
7	5194670-01	Brush Spring Set.....	1
8	5194680-16	Terminal Assembly Package .....	2
9	7204283-00	Drive End Head .....	1
10	7210003-02	Pole Piece.....	4
11	Commercial	3/8" - 16 X 1-1/4" Lg. Hex Screw - Gd. 5.....	8
	Commercial	3/8" Lockwasher .....	8
12	0527100-00	Field Coil Set.....	1
13	7206411-02	Insulator W/Slot .....	2
	7206411-06	Insulator W/O Slot .....	2
14	Commercial	1/4" - 20 X 1" Lg. Hex Screw - Gd. 5 .....	4
	Commercial	1/4" Lockwasher .....	4
15	7205154-02	Armature Assembly .....	1
16	7204574-00	Field Ring.....	1
17	Commercial	3/8" - 16 X 2-1/4" Lg. Hex Screw - Gd. 5.....	6
	Commercial	3/8" Lockwasher .....	6
18	0965971-0A	Bearing Retainer.....	1
19	7203329-01	1/4" - 20 X 1/2" Lg. Self-Locking Screw.....	3
20	0150036-00	1/2" - 20 Elastic Stop Nut.....	1
21	0677133-0F	Bearing .....	1
22	7204273-00	Enclosed Commutator Cover .....	2
23	Commercial	1/4" -20 X 1/2" Lg. Hex Screw .....	4
	Commercial	1/4" Lockwasher .....	4
24	7204263-03	Enclosed Drive End Cover.....	1
25	7204263-08	Pin.....	2
26	Commercial	#10-24 X 2" Lg. Rd. Hd. Screw.....	1
	Commercial	#10-24 Square Nut .....	1

**FOLLOWING ITEMS MUST BE ORDERED SEPARATELY.**

27	7508563-00	Bracket.....	1
	7506651-00	Bracket (Not Shown).....	1
28	5184138-00	Thermostat - 181° F.....	1

**NOTE:** All Commercial Hardware Cadmium Plated.



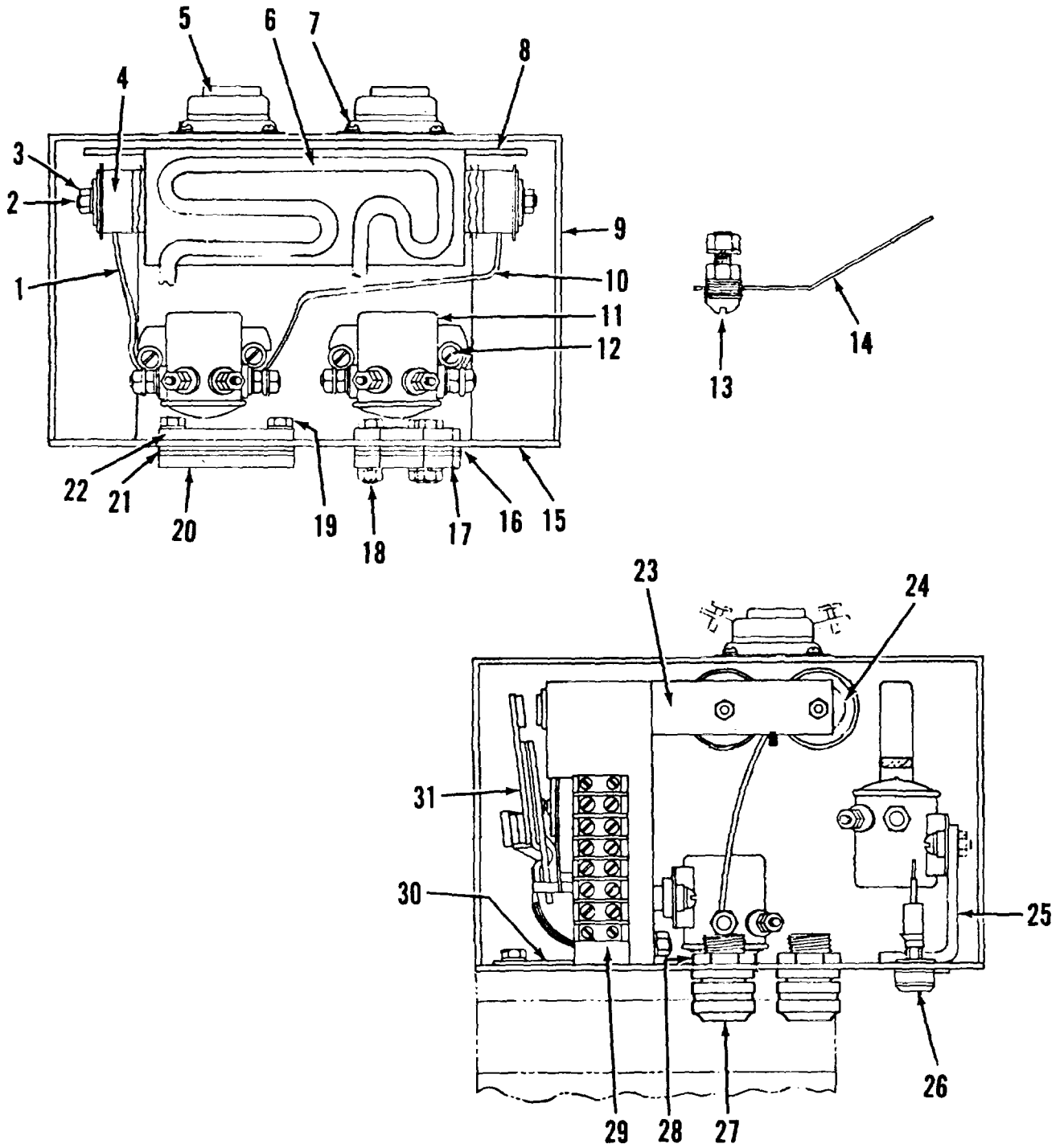

7214140-21 CONTACTOR ASSEMBLY - 12 VOLT - EE

## CONTACTOR ASSEMBLY - 12 VOLT - EE

ITEM	PART NO.	DESCRIPTION	NO. REQD.
1	7205301-01	Connector .....	1
2*	7222601-00	Threaded Rod.....	2
3*	Commercial	10-32 Hex Nut.....	4
	Commercial	10 Lockwasher.....	4
4	1180683-DB	Resistor Assembly - Includes * Items .....	1
5	5184138-00	Thermostat-- 181 e F .....	2
6	7240823-00	Shunt Resistor - .027 Ohms .....	1
7	Commercial	6-32 X 3/8" Lg. Rd. Hd. Screw.....	4
	Commercial	6 Shakeproof Lockwasher. ....	4
8	7237004-00	Heat Shield .....	1
9	7237034-00	Cover .....	1
	5004949-05	"O" Ring .....	1
10	1339213-04	Connector .....	1
11	5012703-04	Contactore - Single Pole.....	3
12	Commercial	1/4" - 20 X 1" Lg. Rd. Hd. Screw .....	4
	Commercial	1/4" Shakeproof Lockwasher .....	4
13	Commercial	3/8" - 16 X 1-3/4" Lg. Brass Rd. Hd. Screw (Shunt Terminal).....	1
	Commercial	3/8" -16 Brass Hex Nut .....	2
	Commercial	3/8" Shakeproof Lockwasher .....	1
	5058361-00	3/8" Insulator Washer .....	2
	5002179-01	3/8" Special Brass Flat Washer .....	2
	5023919-02	3/8" Special Brass Flat Washer .....	3
14	6213851-0B	Shunt Terminal Mounting Bracket .....	1
15	7229246-01	Mounting Plate.....	1
16	6200261-00	Rubber Spacer.....	2
17	6202491-00	Spacer Plate .....	2
18	Commercial	1/4" - 20 X 1-1/4" Lg. Rd. Hd. Screw .....	3
	Commercial	1/4" - 20 Hex Nut .....	3
	Commercial	1/4" Shakeproof Lockwasher.....	3
19	Commercial	1/4" - 20 X 3/4" Lg. Rd. Hd. Screw .....	2
	Commercial	1/4" Shakeproof Lockwasher .....	2
20	6202471-00	Threaded Plate .....	1
21	6200301-00	Rubber Spacer.....	2
22	6202501-00	Plate.....	1
23*	7236573-01	Bracket - (Shown) .....	1
	7236573-02	Bracket - (Opposite) .....	1
24	7222581-00	Reducer Washer.....	4
25	6213851-0A	Bracket .....	1
26	5008641-00	Fuse Post-- Less Fuse .....	1
	5009031-03	15 Amp Fuse .....	1
27	6202941-0L	Sparkproof Connector .....	3
	6202941-0M	Rubber Grommet.....	3
28	0103737-00	3/8" Electrical Conduit Nut .....	3
29	5016441-04	Terminal Block.....	1
30	6200341-00	Insulator-- For Contactore.....	1
31	0954704-AX	Reversing Contactore Assembly .....	1
	7240843-00	Wire Harness - For Contactores .....	1
32	7211711-00	Power Wires Group - Drive Motor - (Not Shown) .....	1

NOTE: Thermostats and 15 Amp Fuse Must be Ordered Separately.  
All Commercial Hardware is Cadmium Plated.

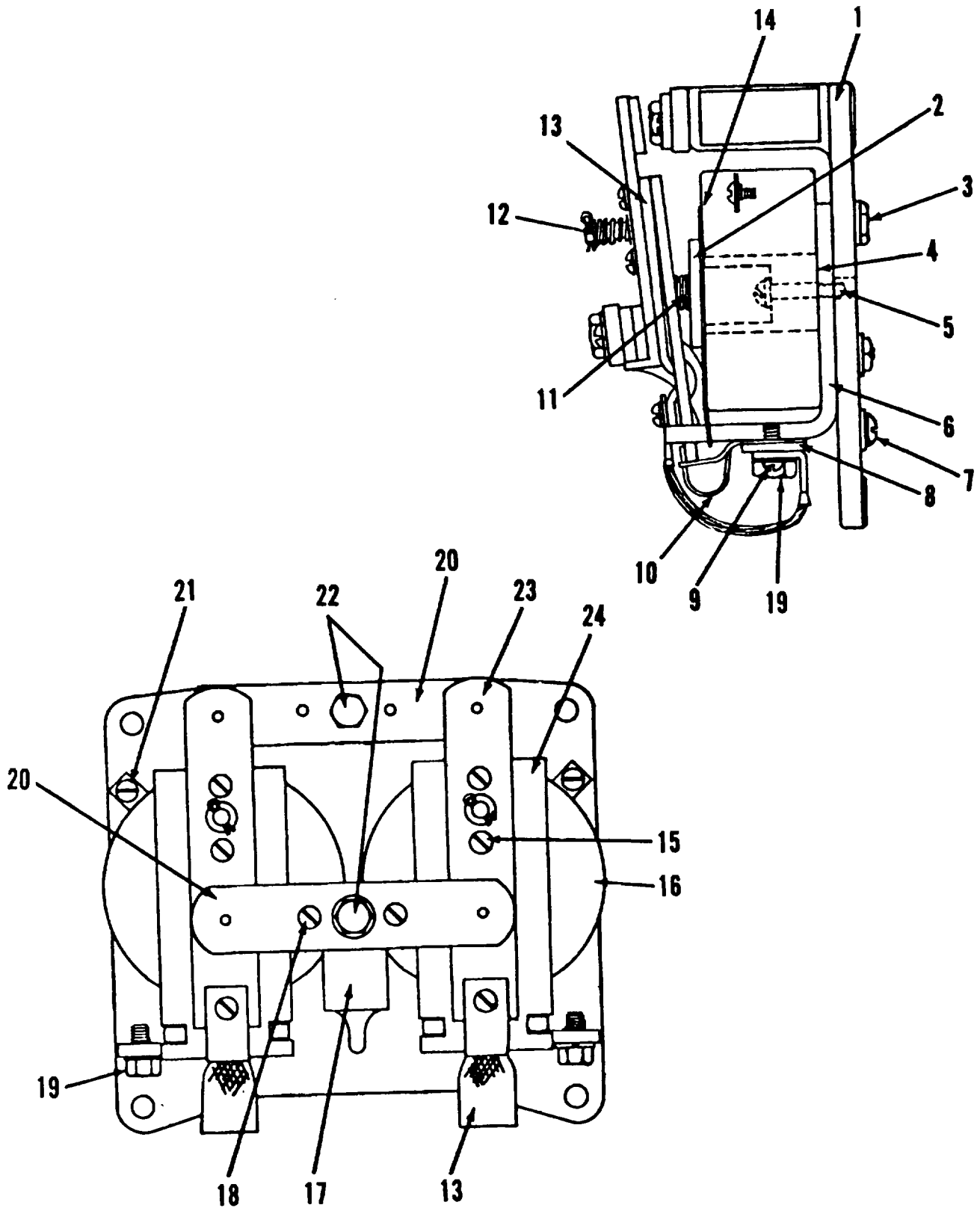

0954704-AX REVERSING CONTACTOR ASSEMBLY - 12 VOLT

## REVERSING CONTACTOR ASSEMBLY - 12 VOLT

ITEM	PART NO.	DESCRIPTION	NO. REQD.
1	0912724-0A	Base.....	1
2	7213531-01	Magnet Core.....	2
	0159153-00	Retaining Ring.....	2
3	5004859-04	#10-24 X 3/4" Lg. Flathead Screw.....	4
	0318984-00	#10 Flat Washer 7/32" Inside Diameter.....	4
	0150357-00	#10 Internal Tooth Shakeproof Lockwasher.....	4
	0318987-00	#10-24 Hexagon Nut.....	4
4	0938261-0W	Magnet Core Shim.....	2
5	7201259-01	#10-24 X 1-1/4" Long Brass Round Head Sems Screw.....	2
6	7213541-01	Magnet Frame.....	2
7	7201249-03	#10-24 X 3/4" Lg. Round Head Sems Screw.....	2
	0318984-00	#10 Flat Washer 7/32" Inside Diameter.....	2
8	0938261-0G	Connector.....	2
9	7201249-02	#10-24 X 5/8" Lg. Round Head Sems Screw.....	2
10	1045681-0A	Shunt Clamp.....	2
11	0938261-0H	Spring.....	2
12	0938261-0K	Cup Washer.....	4
	0938261-0J	Spring.....	2
	Commercial	5/64" Diameter X 1/2" Long Cotter Pin.....	2
13	7210663-01	Moving Contact Support and Shunt Assembly.....	2
14	0236528-00	Spring Washer.....	2
15	7201269-01	#8-32 X 5/16" Long Fillister Head Sems Screw.....	4
16	6050853-0A	Coil - 12 Volt.....	2
17	0928813-0A	Support.....	1
18	7201269-02	#8-32X 1/2" Long Fillister Head Sems Screw.....	2
19	7201289-03	1/4" - 20 X 5/8" Long Hexagon Head Sems Screw.....	4
20	6040231-00	Stationary Contact.....	2
21	7201159-01	#8-32 X 3/8" Long Brass Binding Head Screw.....	4
22	0638297-00	1/4" - 20 X 3/4" Lg. Phillips Head Sems Screw.....	2
23	6040211-00	Moving Contact.....	2
24	7206201-00	Armature.....	2

**NOTE:** All Hardware Cadmium Plated, Unless Otherwise Specified.

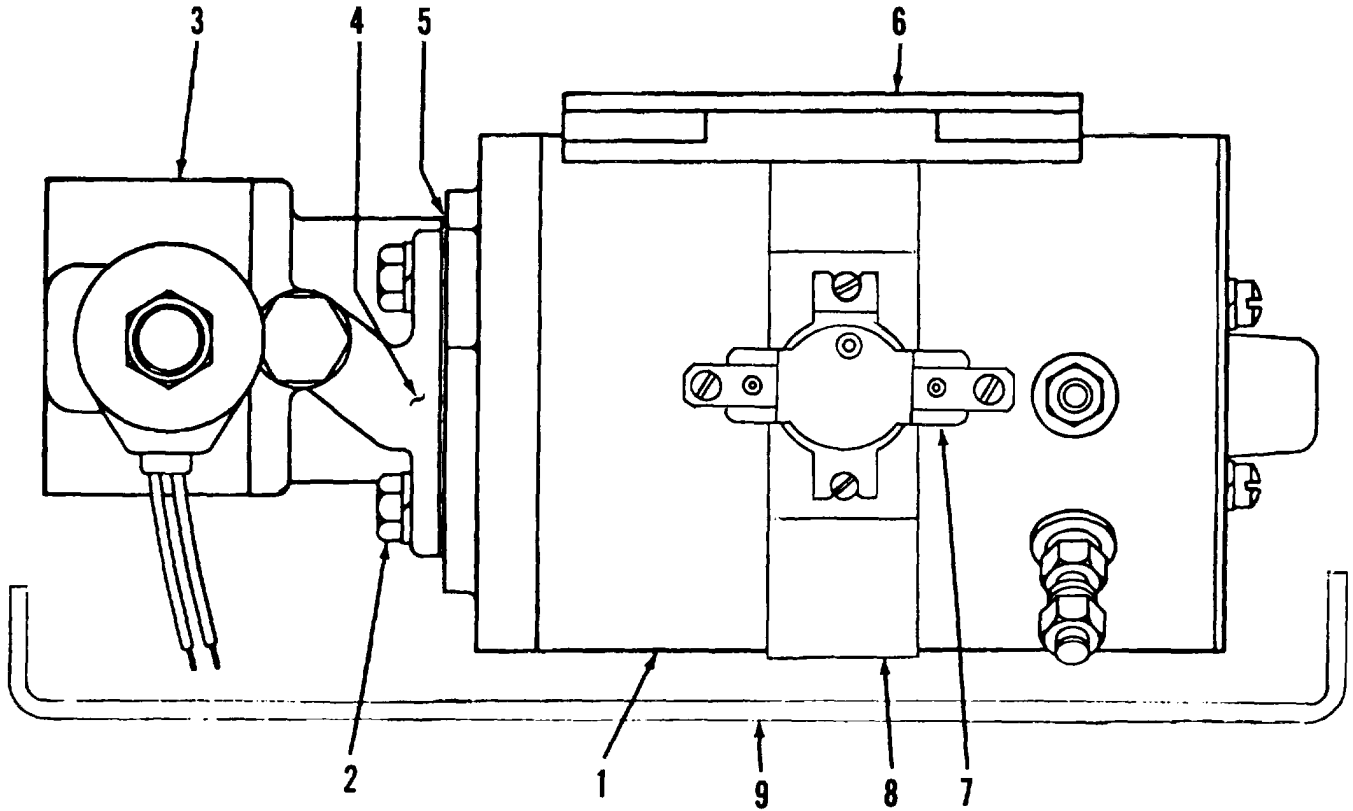

7225514-00 PUMP, MOTOR & RELEASE VALVE - 12 VOLT

ITEM	PART NO.	DESCRIPTION	NO. REQD.
1	7225514-02	Motor 12 Volt .....	1
2	Commercial	5/16" -18 X 3/4" Lg. Hex Screw .....	4
	Commercial	5/16" Lockwasher .....	4
3	7225514-01	Hydraulic Pump W/Release Valve 12 Volt.....	1
4	6106534-0C	Coupling - Pump to Motor.....	1
5	6106534-04	Gasket .....	1
6	5157448-01	Foot.....	1
	Commercial	3/8" - 16 X 1/2" Lg. Rd. Hd. Screw .....	4

**FOLLOWING ITEMS MUST BE ORDERED SEPARATELY.**

7	5184138-00	Thermostat -181° F.....	1
8	7508553-00	Bracket.....	1
9	7224163-00	Splash Pan .....	1

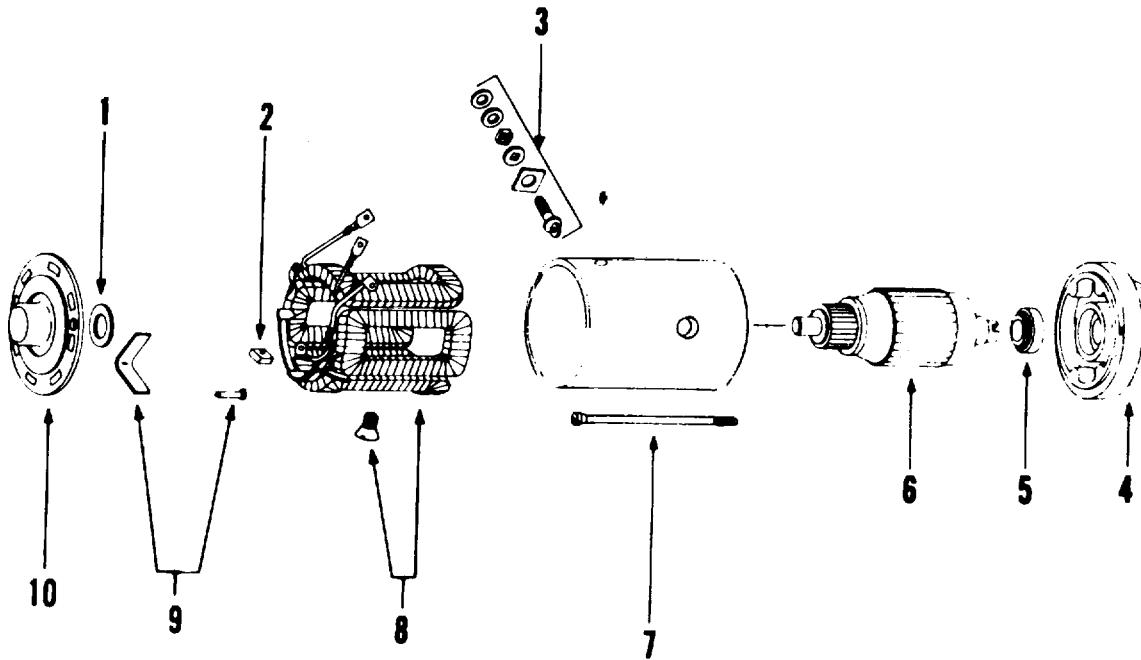

7225514-02 MOTOR - 12 VOLT - HYDRAULIC LIFT PUMP

ITEM	PART NO.	DESCRIPTION	NO. REQD.
1	5062148-00	Thrust Washer Package .....	1
2	0614994-00	Brush Set .....	1
3	5112768-00	Terminal Stud Package .....	1
4	5103288-14	Drive End Head .....	1
5	0151268-00	Drive End Bearing.....	1
6	0662980-00	Armature .....	1
7	5112788-00	Thru Bolt Package (contains 2 thru bolts) .....	1
8	5090138-15	Field Coil Package .....	1
	5125078-06	Lead Assembly .....	1
9	5062138-00	Brush Spring Package (contains 2 springs) .....	1
10	0616327-00	Commutator End Head.....	1

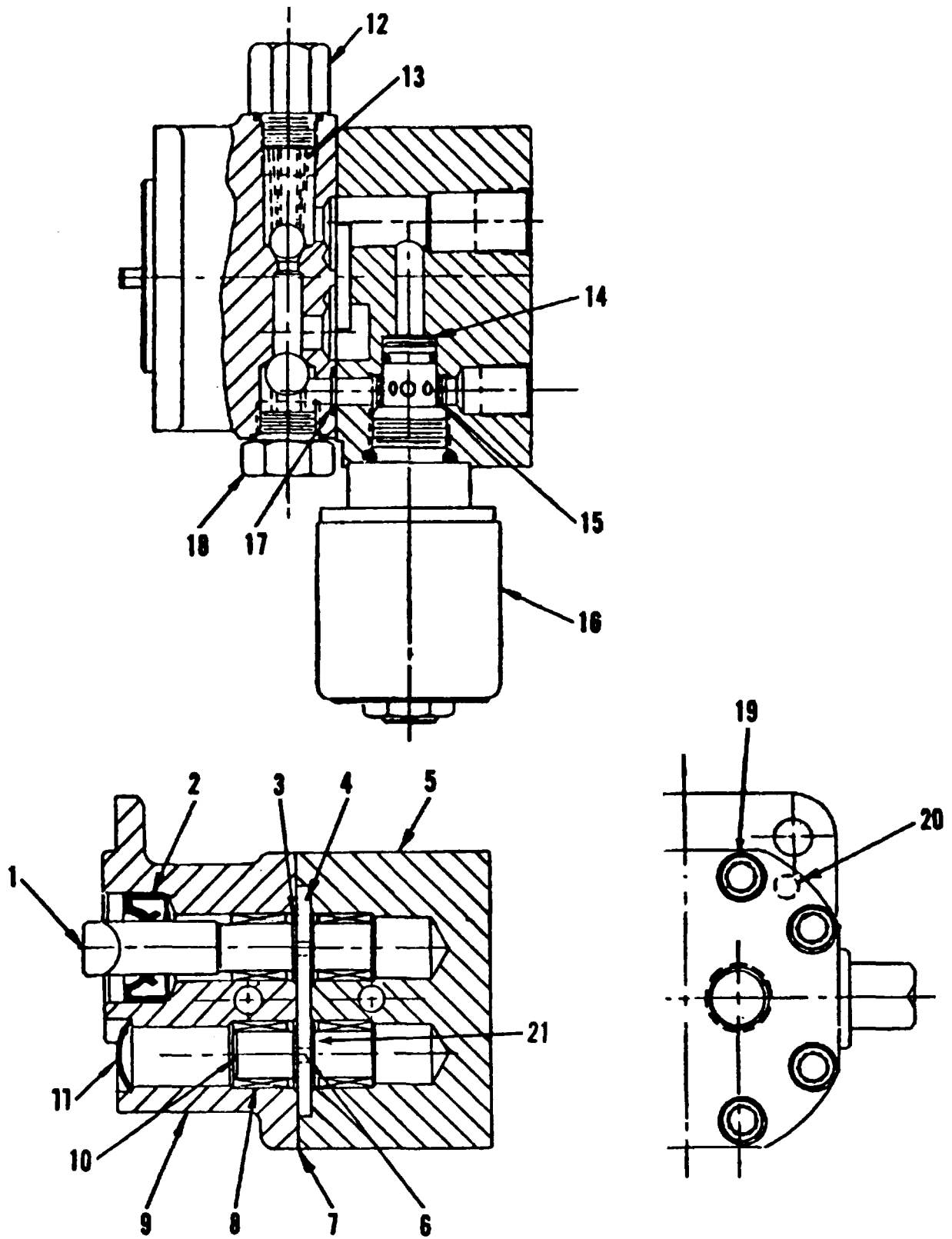

7225514-01 HYDRAULIC PUMP W/SOLENOID RELEASE VALVE - 12 VOLT

HYDRAULIC PUMP W/SOLENOID RELEASE VALVE

ITEM	PART NO.	DESCRIPTION	NO. REQD.
1	0508169-00	Drive Shaft for 1/4" Wide Gear .....	1
	0508171-00	Key.....	1
2	0508168-00	Oil Seal .....	1
3	0508170-00	Snap Ring - Drive Shaft.....	2
4	5048808-00	Gear 1/4" Wide 12 Volt .....	2
5		N.S.S. Stator .....	1
6	5032098-00	Drive Pin .....	1
7	0665030-00	Gasket .....	1
8	0312977-00	Needle Bearing.....	4
9		N.S.S. Housing.....	1
10	5024388-00	Idler Shaft for 1/4" Wide Gear .....	1
11	0568834-00	Wrench Plug .....	1
12	5048838-00	Hex Cap Nut .....	1
	0501066-00	Gasket .....	1
13	0501070-00	Adjusting Screw .....	1
	0665018-00	Spring and Ball Assembly.....	1
	0501063-00	Spring .....	1
14	7230291-01	Orifice Plate (.078" Restriction) .....	1
15*	5157438-01	Filter .....	1
16	7225514-03	Solenoid Release Valve 12 Volt .....	1
17	0128286-00	"O" Ring .....	1
18	5051498-00	Cap .....	1
	5051568-00	Gasket .....	1
	5048828-00	Spring and Ball Assembly.....	1
19	Commercial	1/4" - 20 X 1-3/4" Lg. 12 Point Hd. Screw .....	8
	Commercial	1/4" Moly Lockwasher.....	8
20	5156898-03	Dowel Pin.....	2
21	0662939-00	Snap Ring - Idler Shaft .....	2

NOTES: \* Filter Must be Replaced Anytime Solenoid Release Valve is Removed.  
 N.S.S. - Not Serviced Separately.



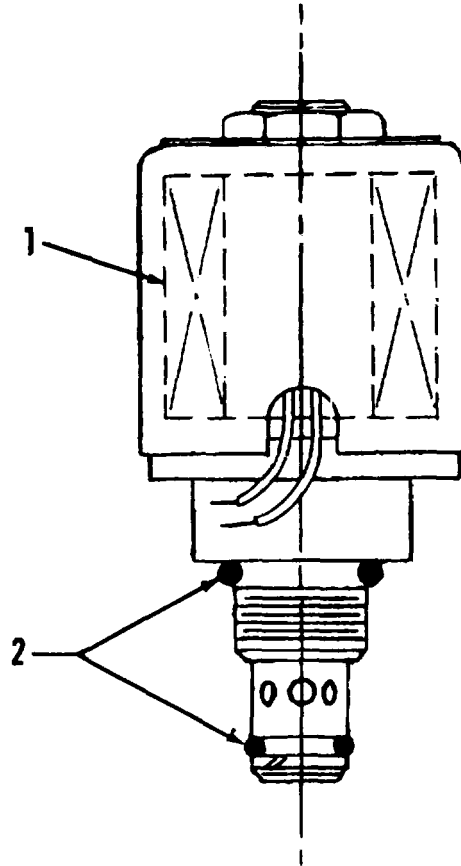

7225514-03 SOLENOID RELEASE VALVE - 12 VOLT

ITEM	PART NO.	DESCRIPTION	NO. REQD.
1	5157458-01	Coil - 12 Volt .....	1
2	5157468-01	Seal and Back-Up Washer Kit .....	1

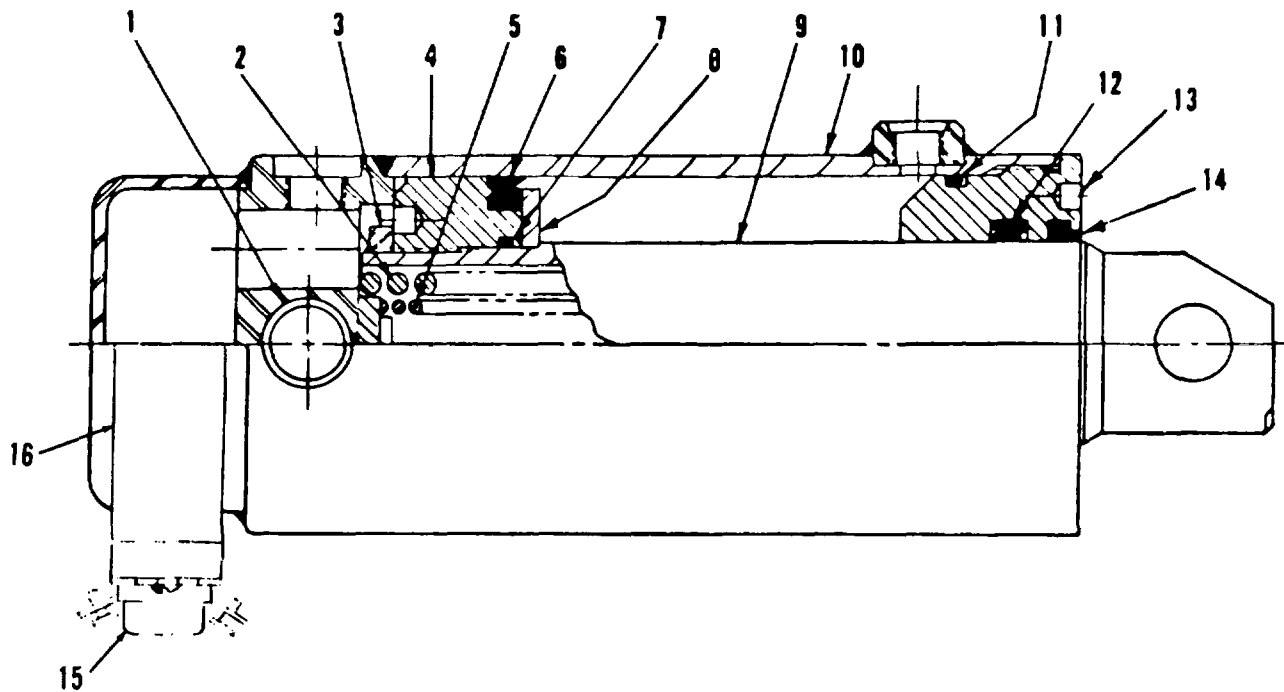

**CAUTION: SPRING LOADED. REFER TO HYDRAULIC SYSTEM MAINTENANCE - LIFT CYLINDER**

*5171754-01 LIFT CYLINDER - CORROSIONPROOF - MP 4000*

ITEM	PART NO.	DESCRIPTION	NO. REQD.
1	5018879-10	Bushings .....	2
2	5150728-00	Spring .....	1
3	5150271-00	Piston Retainer .....	1
4	5161643-00	Piston .....	1
5	5150738-00	Spring .....	1
6	5023749-02	Packing .....	1
7	501881 9-01	"O" Ring .....	1
	5020119-11	Back-Up Ring.....	1
8	5150281-00	Backing Plate.....	1
9	5161983-01	Piston Rod .....	1
10	5171744-01	Tube Weldment .....	1
11	0154924-00	"O" Ring .....	1
	5020119-10	Back-Up Ring.....	1
12	5149978-01	Packing .....	1
13	5161633-00	Gland .....	1
14	5004529-14	Wiper Ring .....	1

**FOLLOWING ITEMS MUST BE ORDERED SEPARATELY.**

15	5184138-00	Thermostat - 181 ° F.....	1
16	5007712-00	Bracket.....	1
17	5152290-00	Packing Kit.....	1

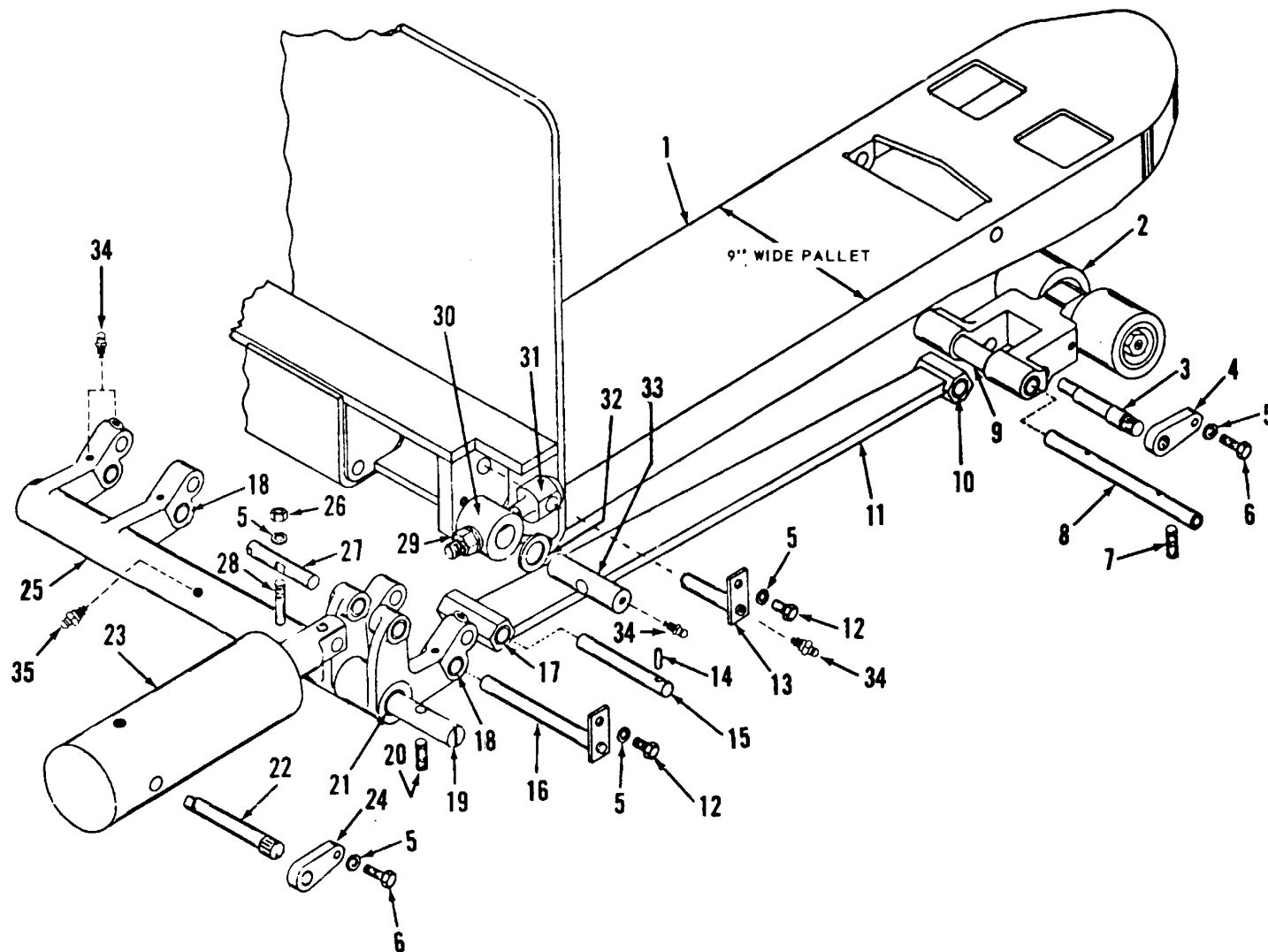

**9" WIDE PALLET & LIFT LINKAGE**

*9" WIDE PALLET & LIFT LINKAGE*

ITEM	PART NO.	9" WIDE PALLET & LIFT LINKAGE DESCRIPTION	NO. REQD.
1	7220906-33	9" Pallet Fork Weldment - 27" Wide X 42" Long .....	1
2	7215090-01	Load Wheel Group - (Refer to Page 32).....	2
3	7222703-00	Eccentric Shaft.....	1
4	7207511-00	Shaft Lock.....	2
5	Commercial	3/8" Lockwasher .....	8
6	Commercial	3/8" - 16 X 1"Lg Hex Screw .....	3
7	Commercial	1/2" - 13 X 1-1/4" Lg. Cup Point Set Screw - Torque 75-85 ft. lbs,.....	2
8	7225811-00	Axle Link Pin .....	2
9	6201991-00	2" Spacer .....	2
10	5018879-10	Bushing.....	4
11	7221764-21	R.H. Pull Rod W/Bushings - (Shown) .....	1
	7221774-21	L.H. Pull Rod W/Bushings - (Opposite) .....	1
12	Commercial	3/8"- 24 X3/4"Lg. Hex Screw .....	4
13	7225791-00	Pin Assembly .....	2
14	Commercial	1/4" - 20 X 3/4" Lg. Cup Point Set Screw.....	2
15	6212171-00	Pin.....	2
16	7225801-00	Shaft Assembly.....	2
17	5001939-07	Bushing.....	4
18	7228011-01	Bushing .....	4
19	7225143-01	Rocker Shaft .....	1
20	Commercial	1/2" - 13 X 1" Lg. Half Dog Point Set Screw - Torque 75-85 ft. lbs.....	2
21	7203379-02	Bushing .....	2
22	7222483-00	Pivot Shaft .....	1
23	5171754-01	Lift Cylinder (Refer to page 29).....	1
24	7207511-00	Shaft Lock.....	1
25	7220536-00	Rocker Arm W/Bushings .....	1
26	Commercial	3/8" - 24 Hex Nut .....	1
27	7226821-00	Pin .....	1
28	7228211-00	Lock Pin .....	1
29	7200029-01	Locknut .....	4
30	6212243-00	Collar .....	1
31	7222493-00	Adjusting Stud W/Locknut .....	2
32	6215911-00	Thrust Washer .....	2
33	5061603-00	Pin.....	2
34	0156287-00	1/4" - 28 Straight Lube Fitting .....	8
35	5021399-01	1/8" Pipe Thread Lube Fitting .....	1

**FOLLOWING ITEMS NOT SHOWN**

1302683-10	Bushing - In Frame for Item 33 .....	2
5001939-10	Bushing - In Frame for Item 33.....	2

**NOTE:** All Commercial Hardware to be Cadmium Plated.

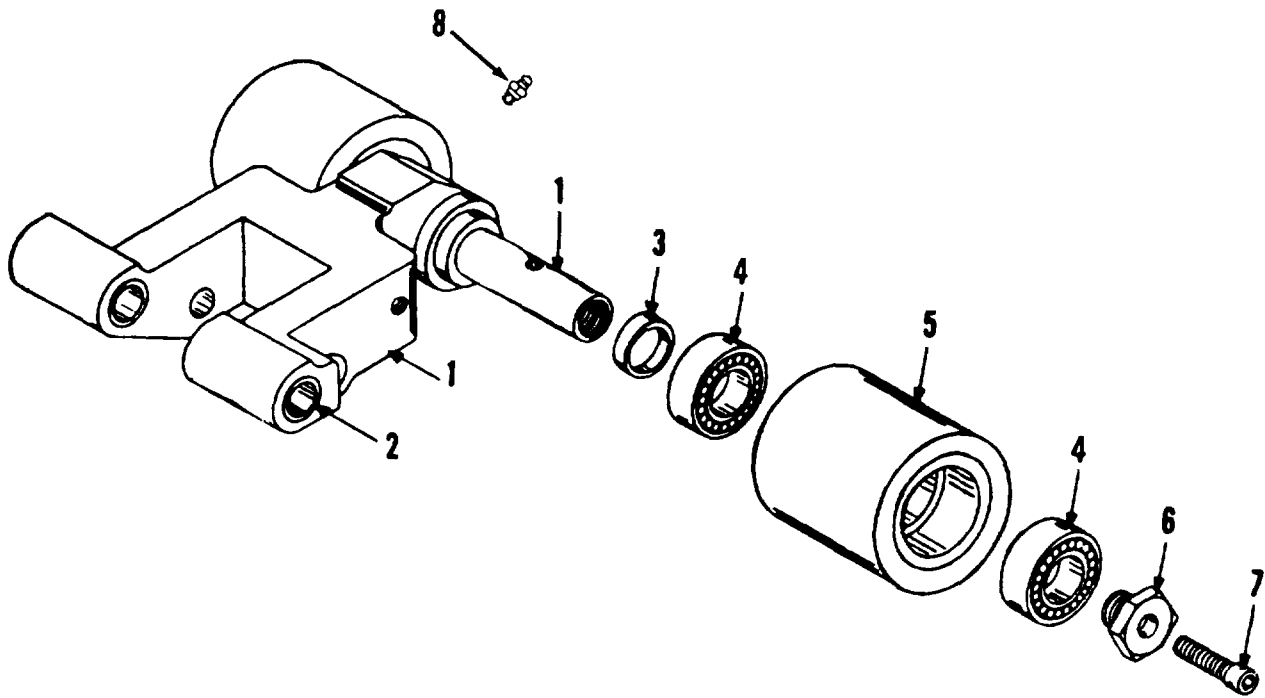

7215090-01 POLY LOAD WHEEL ASSEMBLY - 9" WIDE PALLET FORK

ITEM	PART NO.	DESCRIPTION	NO. REQD.
1	7223303-00	Link and Axle - Includes Item 2 .....	2
2	5001939-07	Bushing.....	8
3	1213571-00	Spacer .....	4
	0624459-00	Spacer Washer .....	4
4	5001209-03	Ball Bearing.....	8
5	1213591-00	Poly Load Wheel 3-3/8" Dia. X 2-3/4".....	4
6	1213601-00	Locknut .....	4
7	0655780-00	5/16" - 24 X 1-1/4" Lg. Soc. Hd. Screw.....	4
8	0156287-00	1/4" - 28 Straight Lube Fitting .....	1

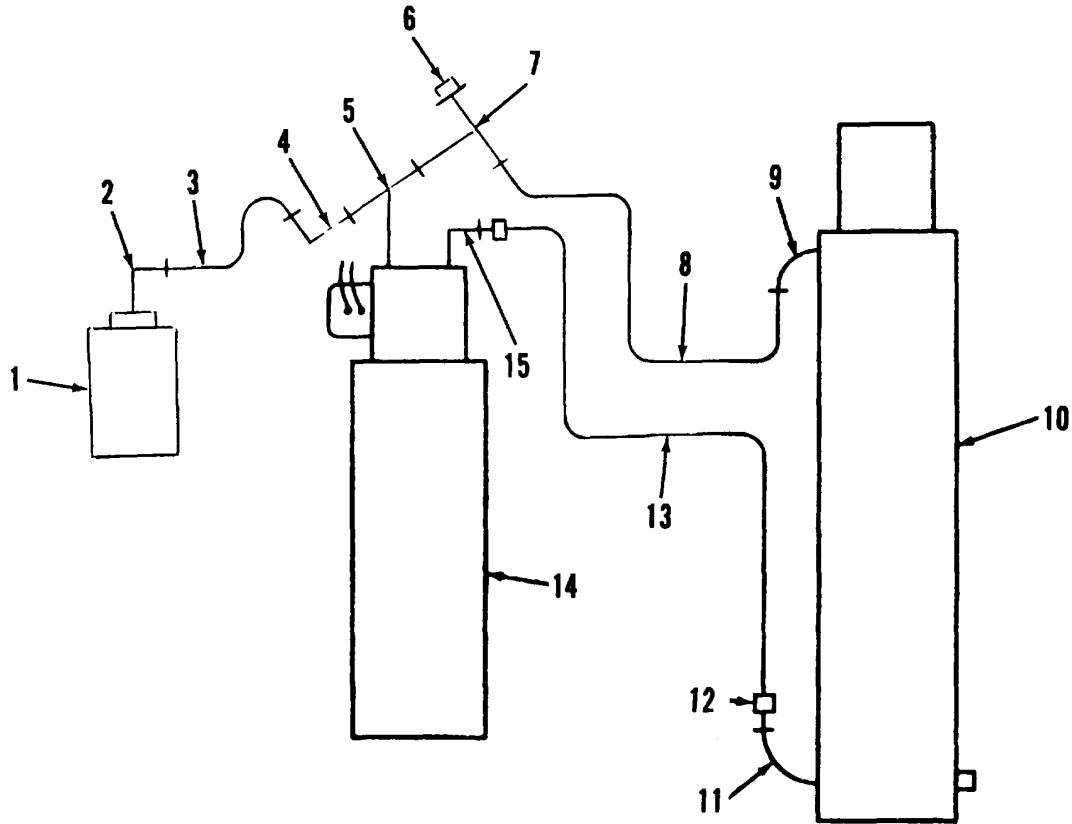

7509204-00 HYDRAULIC DIAGRAM

ITEM	PART NO.	DESCRIPTION	NO. REQD.
1	5007822-00	Pressure Switch .....	1
2	Commercial	45 a Elbow --1 /8" Male Pipe Thd. to 9/16" - 18 Male Thd. * .....	1
3	** 7201079-01	#6 Hose - 7" Long.....	1
4	Commercial	90 Elbow - 1/4" Male Pipe Thd. to 9/16" Male Thd * .....	1
5	Commercial	Pipe Tee - 1/4" Male X 1/4" Female X 1/4" Female.....	1
6	Commercial	Cap Nut- 9/16" - 18 Female Thd.* .....	1
7	Commercial	Tee- 1/4" Male Pipe Thd. X Two 9/16" - 18 Female Thd.....	1
8	** 5024139-39	#5 Hose-21-1/2"Long.....	1
9	Commercial	90 * Elbow - 9/16" - 18 "O" Ring to 916" - 18 Male Thd. * .....	1
	0526452-00	"O" Ring .....	1
10	5171754-00	Lift Cylinder .....	1
11	Commercial	90 * Barbed Elbow - 3/8" Male Pipe Thd. to 5/8" Hose.....	1
12	0621595-00	Hose Clamp .....	2
13	Commercial	Hose - 5/8" Dia. X 27" Long.....	1
14	7225514-02	Pump & Motor.....	1
15	Commercial	90 * Barbed Elbow- 3/8" Male Pipe Thd. to 5/8" Hose.....	1

\* All 9/16" - 18 Thd. Fittings are 37° Flared.  
 \*\* Hose couplings are 9/16" - 18 Female Swivel.  
 \*\* Pressure Hoses burst pressure is 10, 000 PSI.

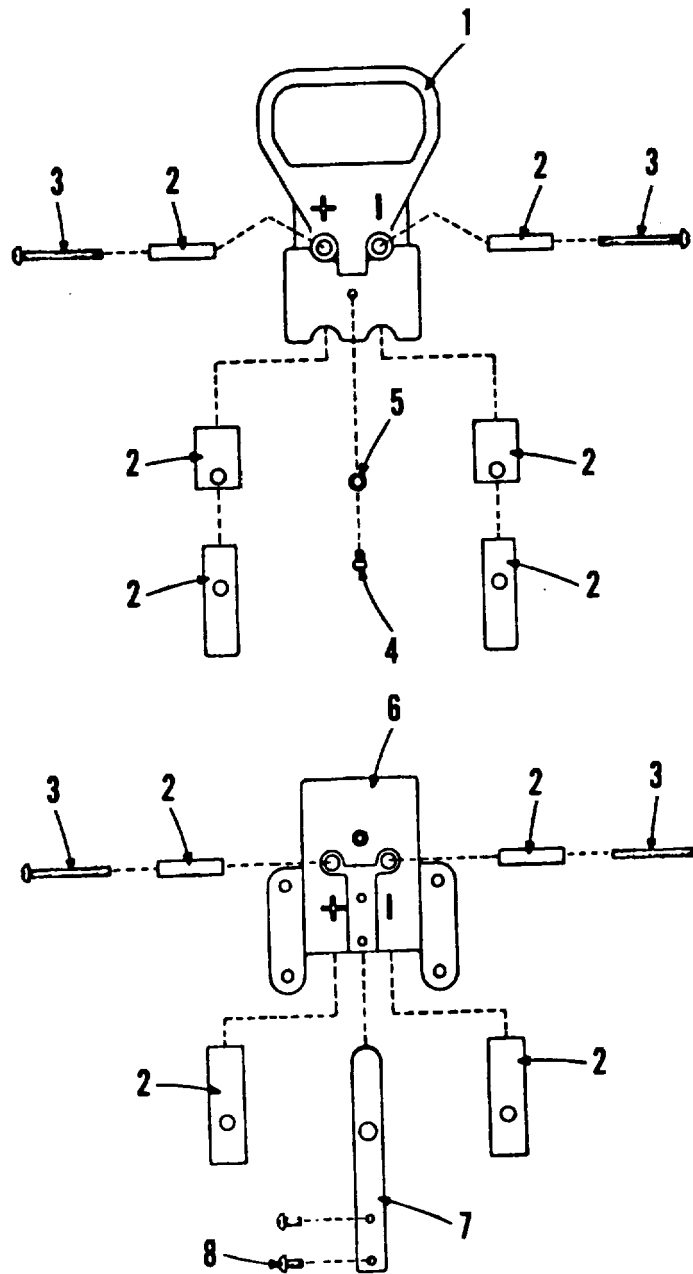

BATTERY PLUG AND RECEPTACLE

ITEM	PART NO.	DESCRIPTION	NO. REQD.
1	0260226-00	Battery Plug Assembly.....	1
2	5167640-02	Contact Kit .....	1
3	Commercial	10-24X 1-3/4" Lg. Rd Hd Screw - Included In Kit.....	4
4	Commercial	10-24 X 1/4" Lg. Fillister Hd. Screw .....	1
5	Commercial	10 Lockwasher.....	1
6	7209400-49	Receptacle Assembly W/Wires .....	1
	0260252-00	Receptacle Assembly - Only.....	1
7	0282593-00	Spring Clip .....	1
8	0148899-00	10-24 X 3/8" Lg Rd. Hd. Sems Screw .....	2

**RECOMMENDED SCHEDULE OF SAFETY AND MAINTENANCE CHECKS**

**EVERY 8 HOURS OR DAILY** - Safety and Operational Checks to be preformed by the Operator.

- General Condition
- Steering
- Brakes
- Drive Control
- Hoist - Lower Controls
- Horn
- Drive Tire - Load Wheels - (Remove foreign particles)
- Battery Charge - Specific Gravity 1150

**EVERY 200 HOURS OR MONTHLY** - Maintenance Checks

- Lubricate all greasing points     }
- Lubricate all oiling points        } Refer to Lubrication Schedule
- Hydraulic oil level                 }
- Lift Cylinder leaks
- Hose and fitting leaks
- Hydraulic Pump noise and operation
- Positive braking at handle
- Clean-blow-out all controls
- Control switch (reversing and traction) in handle
- Reversing contactor (on controller)
- Contactor tips (for burning)
- Cutout switch (for positive action)
- Drive and Pump Motors - commutator  
  brushes  
  brush springs
- Battery connector

**EVERY 400 HOURS OR EVERY 2 MONTHS** - Maintenance Checks

- Clean and repack load wheel bearings
- Drive unit gear box oil level
- Drive motor mounting bolts
- Drive wheel mounting bolts - torque 140-160 ft. lbs. dry

**EVERY 1200 HOURS OR EVERY 3 MONTHS** - Maintenance Checks

- Drain and refill drive unit gear box
- Brake shoe linings
- All wire connections
- Unusual noises



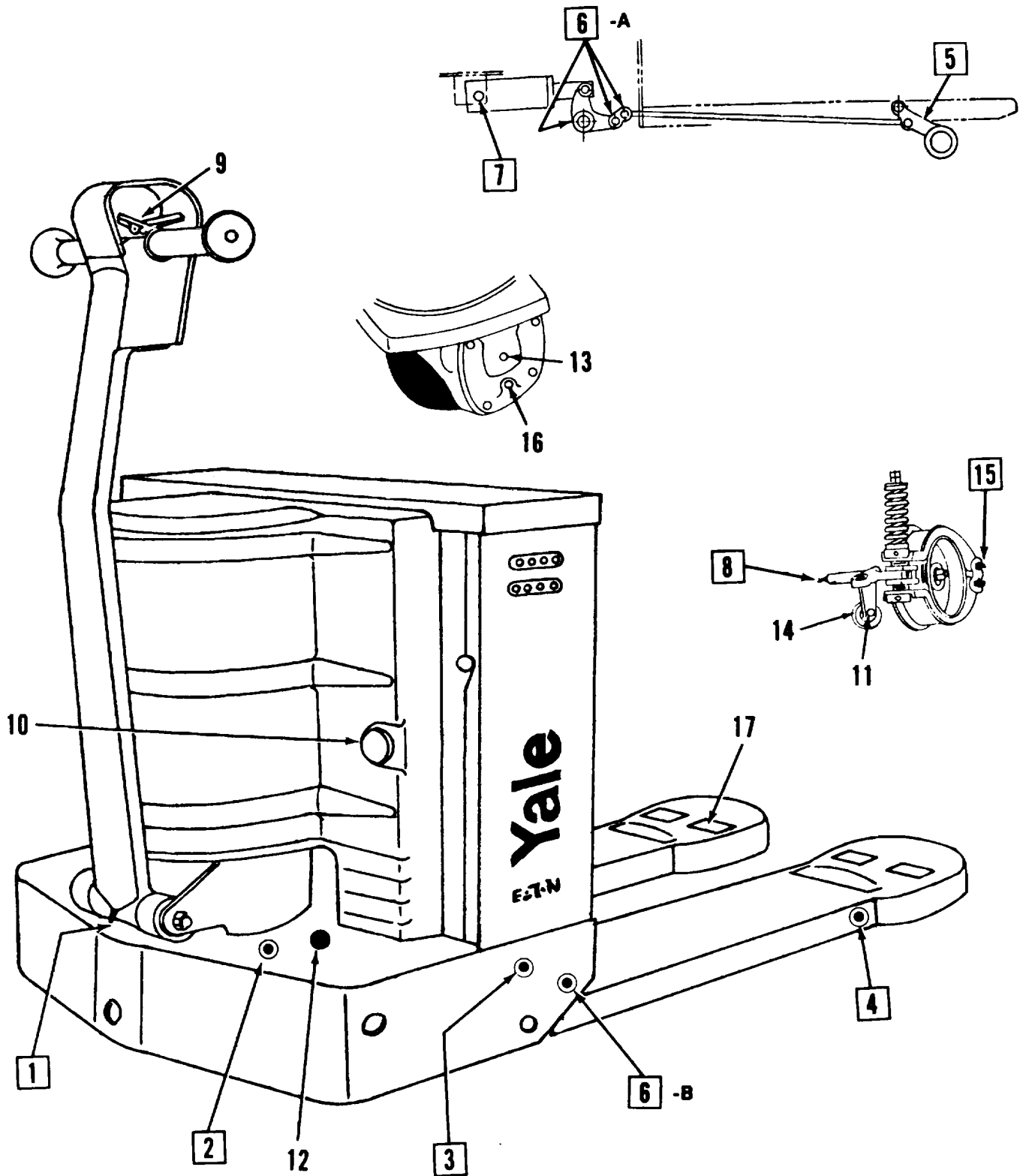

LUBRICATION CHART  
MP 40 LOW LIFT PALLET TRUCK

**SCHEDULE OF LUBRICATION  
MP 40 LOW LIFT PALLET TRUCK**

**EVERY 200 HOURS OR MONTHLY** - Apply grease with Alemite high pressure gun. (Refer to Standard Lubricant List)  
 Before Lubrication - Wipe fittings with a clean cloth.  
 After Lubrication - Wipe excess grease from fittings.

<b>Lubrication Points</b>	<b>No. of Points</b>
1. Steer Handle Pivot Shaft .....	
1	
2. Drive Unit Ring Bearing - Both Sides .....	
2	
3. Adjusting Stud Pin - Both Sides.....	
2	
4. Load Wheel Link Pin - Both Sides of Both Pallet Forks .....	
4	
5. Load Wheel Axle - Elevate Pallet Forks .....	
2	
6A. Rocker Arm - Elevate Pallet Forks .....	
7	
6B. Adjusting Stud Pins - Thru Access Holes, Both Sides of Truck .....	
2	
7. Lift Cylinder Eccentric Pin - Near, Underside of Truck .....	
1	
8. Brake Cam - Remove Drive Unit Cover.....	
1	

**EVERY 200 HOURS OR MONTHLY** - Apply SAE 20 or 30 oil with a spout can to all moving parts.

- 9. Travel Control Plate
- 10. Knobs - Remove Drive Unit Cover
- 11. Brake Cam Roller - Remove Drive Unit Cover

**EVERY 200 HOURS OR MONTHLY - CHECK OIL LEVEL - (Refer to Standard Lubricant List)**

- 12. Hydraulic Oil - Lift cylinder ram must be in extended position. Remove cylinder filler plug thru access hole in truck frame Oil level should be 1 /8" below inside diameter of lift cylinder.

**EVERY 400 HOURS OR EVERY 2 MONTHS - (Refer to Standard Lubricant Lists)**

- 13. Check Gear Oil Level - Remove drive unit level plug, the oil should run out slightly. To add oil, leave oil level plug out while filling at breather plug in gear box top cover, until oil runs out level hole Replace both plugs.
- 14. Apply Paratac Grease to Brake Cam and roller. Remove Drive Unit Cover.
- 15. Brake Shoe Pivot Pin - (2) Points - Remove Drive Unit Cover.

Caution must be taken when greasing brake shoe pivot pins not to allow excess grease to get on brake shoe linings which could cause brake failure. An extra precaution such as removing these lube fittings would be safe.

**EVERY 1200 HOURS OR EVERY 3 MONTHS - (Refer to Standard Lubricant List)**

- 16. Gear Oil - Drain drive unit and refill. Refer to item 13.
- 17. Load Wheel Bearings - Disassemble, clean and inspect bearings for wear or damage. Reassemble and grease.

**NOTE:** Do not expose Bearings or Hydraulic System unnecessarily to foreign particles. Use hands, tools and wipe rags free of all dirt and grit.

**NOTE:** The interval of time referred to in this schedule of lubrication is based on normal operating conditions. If the vehicle is operated in areas of high contamination such as dust, corrosive vapors, etc , the interval of time should be adjusted accordingly.

## Grease

Part Number	0032034-00	0032519-00	0556345-00
Application	High press. fittings Anti-friction brgs.	Wheel bearings Zerk fittings	Where grease retention is desired Open slides, bearings, journals
Type	Grease lithium Multi-purpose No. 2	Grease	Paratac grease lime or aluminum base
Specification	Rust inhibited		
Continuous Operating Temp. °F Intermittent	Above 20° To -40°	+125° to -65°	Above 20°
Mil-Spec.	None	Mil-G-10924A low temp.	None
American (Amoco)	Amolith grease MP	No product	Vesuvius compound "BX"
Atlantic Richfield (Arco)	Litholene H-EP 2	No product	Shamrock heavy
BP Oil Corp.	BP energrease M-P	No product	No product
Burman-Castrol	Castrol BM	No product	Castrol CL
C. F. Kellom & Co.	Poly Moly Lithium EP No. 2	No product	Invader viscous pressure grease
Chevron Oil Co.	Dura-Lith EP 2	No product	No product
Cities Service (Citco)	Lithium No. 2	No product	No product
Exxon	Ronex MP	No product	No product
Fiske Brothers	Lubriplate No. 630-2	No product	No product
Gulf	Gulf Crown EP-2	No product	No product
Houghton & Co.	Cosmolube No. 2	No product	Sta-Put No. 580
Keystone (Pinnwall)	Keystone No. 81 Light	No product	Keystone Chain "B" Medium
Mobil Oil Co. (Mobil)	Mobil Grease MP 2	Mobile Grease MT 502	No product
P. A. Stuart Oil Co. Ltd.	Dasco 3405	No product	Stuart 4501XH Tacky Lube
Pennzoll Oil Co.	Multi-purpose No. 303 or No. 705	No product	Cha-Z-Lube 316
Phillips Petroleum	Philube EP-2	No product	No product
Shell	Alvania No. 2	Shell No. 70922	No product
Sun Oil Co. (Sunoco)	Prestige No. 42	No product	No product
Sunray DX Oil Co.	DX All Purpose No. 646	No product	No product
Texaco	Marfax Multi-purpose No. 2	No product	Geartac "0"
Union Oil Co. of Calif.	Unobar EP-2	Union Low Temp Grease	Union A Grease -2
Valvoline Oil Co. (Ashland)	Val-lith No. 2 EP	Tectyl 858C	D. B. Wheel Brg.

## Gear Oils

Part Number	5018449-01	5018449-03	5018449-04	5018449-05
SAE Grade	75	80	90	140
Type	All Purpose EP	All Purpose EP	All Purpose EP	All Purpose EP
Use for Temperature	As Low As -35° F	As Low As -15° F	As Low As +5° F	As Low As +25° F or Extreme Heavy Duty
Mil-Spec.	Mil-L-2105B	Mil-L-2105B	Mil-L-2105B	Mil-L-2105B
API Service Classification	GL-5	GL-5	GL-5	GL-5
American (Amoco)	Multi-Purpose Gear Lubricant	Multi-Purpose Gear Lubricant	Multi-Purpose Gear Lubricant	Multi-Purpose Gear Lubricant
Atlantic Richfield (Arco)	No product	Arco HD Gear Oil SAE 80-90	Arco HD Gear Oil SAE 80-90	Arco HD Gear Oil SAE 140
BP Oil Corp.	No product	BP Extra Duty Gear Oil 80	BP Extra Duty Gear Oil 90	BP Extra Duty Gear Oil 140
Burman-Castrol	No Product	Castrol Hypoy B SAE 80	Castrol Hypoy B SAE 90	Castrol Hipress SAE 140
Chevron Oil Co.	Chevron Universal Gear Lub 75	Chevron Universal Gear Lub 80-90	Chevron Universal Gear Lub 80-90	Chevron Universal Gear Lub 140
Citiles Service (Citco)	M.P. 80-90	M.P. 80-90	M.P. 80-90	M.P. 85-140
Exxon	No product	Exxon Gear Oil GX 80	Exxon Gear Oil GX 90	Exxon Gear Oil GX 140
Fiske Brothers	Lubriplate APG-75	Lubriplate APG-80	Lubriplate APG-90	Lubriplate APG-140
Gulf	No product	Multi-Purpose Gear Lubricant 80	Multi-Purpose Gear Lubricant 90	Multi-Purpose Gear Lubricant 140
Houghton & Co.	No product	No product	MP Gear Oil 90	MP Gear Oil 140
C. F. Kellom & Co.	No product	Invader MP 80	Invader MP 90	Invader MP 140
Keystone (Pennwalt)	No product	No product	All Purpose No. 1790	All Purpose No. 1791
Mobil Oil Co. (Mobil)	Mobilube SHC	Mobilube HD 80/90	Mobilube HD 80/90	Mobilube HD 85/140
Pennzoll Oil Co.	Multi-Purpose 4075	Multi-Purpose 4092	Multi-Purpose 4092	Multi-Purpose 4140
Phillips Petroleum	No product	Philube SMP Gear Oil	Philube SMP Gear Oil	Philube SMP Gear Oil
Shell	No product	Spirax HD 80/90	Spirax HD 80/90	Spirax HD 85/140
Sun Oil Co. (Sunoco)	No product	Sunfleet GL-5 Gear Oil 80	Sunfleet GL-5 Gear Oil 90	Sunfleet GL-5 Gear Oil 140
Sunray DX Oil Co.	Multi-Purpose DX Gear Lub 75	Multi-Purpose DX Gear Lub 80/90	Multi-Purpose DX Gear Lub 80/90	Multi-Purpose DX Gear Lub 140
Texaco	No product	Multigear 80	Multigear 90	Multigear 140
Union Oil Co. of Calif.	Union MP Gear Lub 75	Union MP Gear Lub 80	Union MP Gear Lub 90	Union MP Gear Lub 140
Valvoline Oil Co. (Ashland)	No product	X-18 MD SAE 80	Multi-Purpose 85/90	SAE 85/140

## Hydraulic Oils

Part Number	5143618-00	0034142-00	0032570-00
Type	Anti-Wear Industrial Hydraulic Oil		
Ambient Air Temp. Condition	Normal	Cold Storage	Arctic
Anticipated Ambient Air Temp. Range	+32° to +110° F	+32° to -25° F	0° to -60° F
Actual Useable Operation Oil Temp. Range	+18° to +148° F	-12° to +113° F	-55° to +65° F
ASTM Viscosity Grade Number	S-215	S-105	S-75
Pour ° F Max.	-20° F	-50° F	-75° F
Mil-Spec.			Mil-H-5606A
American (Amoco)	Rykon No. 21	Rykon No. 11	No product
Atlantic Richfield (Arco)	Duro AW-S-215	No product	No product
BP Oil Corp.	BP Energol HLP-C46	No product	No product
Chevron Oil Co.	Chevron EP Hyd. Oil 46	Chevron EP Hyd. Oil MV	Aviation Hyd. Fluid A
Cities Service (Citco)	Pacemaker XD-20	No product	No product
Exxon	Nuto H 48	No product	Univis J-43
Fiske Brothers	Lubriplate HO-1	No product	No product
Gulf	Harmony 48AW	No product	No product
Houghton & Co.	Hydro Drive HP 200	Cosmolubric 1702	No product
Keystone (Pennwalt)	KLC No. 5	No product	No product
Mobil Oil Co. (Mobil)	DTE 25	DTE 11	AERO-HFA
Pennzoil Oil Co.	Hyd. & Gen. Purp. No. 2	Hyd. & Gen. Purp. No. 0	No product
Phillips Petroleum	Magnus A-215	No product	No product
Shell	Tellus 29	Donax T2	Aeroshell Fluid 4
Sun Oil Co. (Sunoco)	Sunvis 821 WR	No product	No product
Sunray DX Oil Co.	Diamond R.O.Z.A. Oil M	No product	No product
Texaco	Rando HD-215	Rando HD-AZ	Aircraft Hyd. "BB"
Union Oil Co. of Calif.	Union UNAX W-215	No product	No product
Valvoline Oil Co. (Ashland)	Anti-Wear No. 20	Anti-Wear No. 10	No product





## YALE PART NO. TO VENDOR PART NO. (FSCM) CROSS REFERENCE

PAGE	YALE NO.	DESCRIPTION	FSCM	VENDOR NO.	VENDOR NAME
9	7235184-00	12V. Horn	56118	6S-50H	Sparton Corp.
9	5012703-04	12V. Contactor	19728	SAS-5208	Prestolite Div.
9	5152921-00	Mic Switch	04426	10-727021	Licon Div.
14	5029288-00	Ball Bearing	43334	7604	New Departure Div.
14	0151208-00	Ball Bearing	43334	Z99506	New Departure Div.
14	5018029-01	"O" Ring	81168	APR-568-120-716-70	Linear Inc.
14	5182168-00	Expansion Plug	73287	HP-2215-S-83	M. D. Hubbard Co.
14	0567048-00	Ball Bearing	43334	306-SFF#22	New Departure Div.
14	6400469-20	Retaining Ring	81155	IN-281	Eaton Corp.
14	0128288-00	"O" Ring	81168	11-216-7446-70	Linear Inc.
14	5030118-00	Ball Bearing	43334	7508	New Departure Div.
14	5019899-03	Retaining Ring	81155	IN-315	Eaton Corp.
14	0270788-00	Roller Bearing	51588	SJ-7315	Roller Brg. Co.
14	7200049-03	Oil Seal	81596	48128	National Seal Div.
18	0805411-0M	Ball Bearing	29337	99204-HIVA4-E300	Hoover Brg. Co.
18	0677133-0F	Ball Bearing	29337	99205-HIVA4-E300	Hoover Brg. Co.
20	5004949-05	"O" Ring	81168	11-275-7446-70	Linear Inc.
20	5012703-04	12V. Contactor	19728	SAS-5208	Prestolite Div.
24	7225514-00	Pump & Motor	70763	GC-3902-3-A	J. S. Barnes Corp.
24	6106534-0C	Coupling	70763	GC-483	J. S. Barnes Corp.
24	6106534-04	Gasket	70763	PA-7156	J. S. Barnes Corp.
24	5157448-01	Foot	70763	GC-2334-2	J. S. Barnes Corp.
25	7225514-02	Pump Motor	19728	MDY-6120	Prestolite Div.
25	5062148-00	Thrust Washer Package	19728	90-263	Prestolite Div.
25	0614994-00	Brush Set	19728	MDL-2012AS	Prestolite Div.
25	5112768-00	Ter. Stud Package	19728	90-404	Prestolite Div.
25	5103288-14	D. E. Head	19728	MDY-28	Prestolite Div.
25	0151268-00	D. E. Bearing	19728	X-367-SAE 202	Prestolite Div.
25	0662980-00	Armature	19728	MDL-2134A	Prestolite Div.
25	5112788-00	Thru Bolt Package	19728	GJ-20SS	Prestolite Div.
25	5090138-15	Field Coil Package	19728	MDY-2005ES	Prestolite Div.
25	5125078-06	Lead Assembly	19728	MFE-39	Prestolite Div.
25	5062138-00	Brush Spring Package	19728	90-328	Prestolite Div.
25	0616327-00	C. E. Head	19728	MDL-1002	Prestolite Div.
26	7225514-01	Hydraulic Pump	70763	GC-5067-A-19-CA	J. S. Barnes Corp.
26	0508169-00	Drive Shaft	70763	GC-572-C	J. S. Barnes Corp.
26	0508171-00	Square Key	70763	GC-895-C	J. S. Barnes Corp.
26	0508170-00	Snap Ring	70763	GC-219	J. S. Barnes Corp.
26	5048808-00	1/4" Gear	70763	GC-4206-C	J. S. Barnes Corp.
26	5032098-00	Drive Pin	70763	GC-3562	J. S. Barnes Corp.
26	0665030-00	Gasket	70763	GC-2733-B-1	J. S. Barnes Corp.
26	0312977-00	Needle Bearing	70763	PA-8542	J. S. Barnes Corp.
26	5024388-00	Idle Shaft	70763	GC-1430-C	J. S. Barnes Corp.
26	0568834-00	Welsh Plug	70763	GC-1525	J. S. Barnes Corp.
26	5048838-00	Hex Cap Nut	70763	GC-3230	J. S. Barnes Corp.
26	0501066-00	Gasket	70763	PA-7116	J. S. Barnes Corp.
26	0501070-00	Adjusting Screw	70763	PA-8217	J. S. Barnes Corp.
26	0665018-00	Spring & Ball	70763	GC-2915-A-1	J. S. Barnes Corp.
26	0501063-00	Spring	70763	PA-8144	J. S. Barnes Corp.
26	7230291-00	Orifice Plate — 078"	70763	GC-7650-078	J. S. Barnes Corp.

## YALE PART NO. TO VENDOR PART NO. (FSCM) CROSS REFERENCE

PAGE	YALE NO.	DESCRIPTION	FSCM	VENDOR NO.	VENDOR NAME
26	5157438-01	Filter	70763	GC-7015-2	J. S. Barnes Corp.
26	0128286-00	"O" Ring	70763	GC-2423-7	J. S. Barnes Corp.
26	5051498-00	Cap	70763	GC-407-S	J. S. Barnes Corp.
26	5051568-00	Gasket	70763	GC-1169-1	J. S. Barnes Corp.
26	5048828-00	Spring & Ball	70763	GC-2150-A	J. S. Barnes Corp.
26	5156898-03	Dowel Pin	70763	GC-4850-14-8	J. S. Barnes Corp.
26	0662939-00	Snap Ring	70763	GC-1448	J. S. Barnes Corp.
28	7225514-03	Release Valve	70763	GC-7000-B-12-1	J. S. Barnes Corp.
28	5157458-01	12V. Coil	82271	115696-12	Waterman Corp.
28	5157468-01	Seal Kit	82271	115809	Waterman Corp.
29	5023749-02	Piston Packing	72902	5315-3	Greene Tweed Co.
29	5149978-01	Rod Packing	72902	1512-02125-0250-0408	Greene Tweed Co.
29	5018819-01	"O" Ring	81168	11-227-7446-70	Linear Inc.
29	0154924-00	"O" Ring	81168	11-238-7446-70	Linear Inc.
29	5020119-10	Back-Up Ring	08752	8-238	Parker Div.
29	5020119-11	Back-Up Ring	08752	8-227	Parker Div.
32	5001209-03	Ball Bearing	43334	Z9505	New Departure Div.
33	5007822-00	Pressure Switch	89326	96100-BB1	Barksdale Div.
19, 21, 24, 29	5184138-00	Thermostat	06668	20400L29-85L181-1.8	Texas Instrument
9	7237211-00	Diode	81483	20A4	International Rectifier Corp.
21	5009031-03	15 Amp Fuse	71400	ABC15	Bussman Fuse Div.
33	0526452-00	"O" Ring	81168	906-7483-90	Linear Inc.

RECOMMENDED MAXIMUM TIGHTENING TORQUE VALUES FOR SCREWS (IN FOOT- POUNDS)

MARKING		NO MARK 		3 - MARKS 		6 - MARKS 					
SAE GRADE		2		5		8		SOCKET HEAD		FLANGED-12 PT	
SIZE	THD.	DRY LUB.*		DRY LUB.*		DRY LUB.*		DRY LUB.*		DRY LUB.*	
1/4"	20	6	4	8	6	12	9	13	10	16	12
1/4"	28	6	5	10	7	14	10	15	11	18	14
5/16"	18	11	8	17	13	25	18	27	20	33	25
5/16"	24	12	9	19	14	25	20	30	22	36	27
3/8"	16	20	15	30	23	45	35	48	36	58	44
3/8"	24	23	17	35	25	50	35	55	41	66	49
7/16"	14	30	24	50	35	70	55	77	58	93	70
7/16"	20	35	25	55	40	80	60	86	65	104	78
1/2"	13	50	35	75	55	110	80	118	89	142	106
1/2"	20	55	40	90	65	120	90	132	99	160	120
9/16"	12	70	55	110	80	150	110	170	127	205	153
9/16"	18	80	60	120	90	170	130	189	141	228	171
5/8"	11	100	75	150	110	220	170	235	176	283	212
5/8"	18	110	85	170	130	240	180	266	200	320	240
3/4"	10	175	130	260	200	380	280	417	313	501	376
3/4"	16	195	145	300	220	420	320	467	350	559	420
7/8"	9	165	125	430	320	600	460	672	504	707	530
7/8"	14	185	140	470	350	660	500	741	562	778	584
1"	8	250	190	640	480	900	680	1006	756	1060	795
1"	12	270	200	700	530	1000	740	1125	833	--	--
1"	14	340	260	750	580	1030	785	1230	883	1190	892
1-1/8"	7	350	270	800	600	1280	960	1283	966	1702	1276
1-1/8"	12	400	300	880	660	1440	1080	1425	1066	1908	1431
1-1/4"	7	500	380	1120	840	1820	1360	1600	1200	2162	1621
1-1/4"	12	550	420	1240	920	2000	1500	1800	1350	2660	1995
1-3/8"	6	660	490	1460	1100	2380	1780	2362	1782	--	--
1-3/8"	12	740	560	1680	1260	2720	2040	2708	2033	--	--
1-1/2"	6	870	650	1940	1460	3160	2360	2800	2100	4177	3133
1-1/2"	12	980	730	2200	1640	3560	2660	3000	2260	4700	3525

\* The term lub includes the application of thread lubricants, lubricizing cadmium plating and the use of hardened steel washers.



## SERVICE INSTRUCTIONS

Your Yale Industrial Truck dealer is equipped with modern service facilities and mobile service units, staffed by factory trained mechanics and supplied with genuine replacement parts from computer stocked regional parts depots, to perform every service function, from a change of a fuse to a complete truck overhaul.

Your Yale Industrial Truck dealer also has a variety of service maintenance programs, designed to reduce equipment downtime and maintenance costs. Contact your Yale Industrial Truck dealer for further details.

Users are cautioned to operate and service Powered Industrial Trucks in accordance with OSHA section 1910.178 and ANSI B56.1 and B56.2 standards.

Contained on Page 35 is our Recommended Schedule of Maintenance for hourly service intervals. Regular attention at the specified time, will pay dividends in maximum efficiency and longer truck life.

### HINTS FOR SAFE MAINTENANCE

Your Yale truck, as manufactured, meets all the applicable mandatory requirements of ANSI B56.1 - 1969 Safety Standard for Powered Industrial Trucks. In addition, this truck conforms to the Underwriters Laboratories requirements for the "EE" Type Designation shown on the capacity plate.

No additions, omissions or modifications should be made that will affect compliance to the above requirements

The following instructions have been prepared for your safety and the safety of your fellow workers during maintenance operations and should be strictly adhered to. Carefully read and understand each one and read the maintenance procedures before attempting to repair the truck. When in doubt of any maintenance procedure, contact your local Yale dealer.



## CAUTION

1. Powered Industrial truck may become hazardous if adequate maintenance is neglected. Therefore, adequate maintenance facilities, personnel and procedures should be provided.
2. Page 35 contains a recommended schedule of preventive maintenance and should be used as a guide for inspection of the truck.
3. Only qualified and authorized personnel should be permitted to maintain, repair, adjust and inspect this truck.
4. The work area should be properly ventilated. Keep shop clean and floor dry
5. Avoid fire hazards and have fire protection equipment present. Do not use an open flame to check level, or for leakage, of electrolyte. Do not use open pans of fuel or flammable cleaning fluids for cleaning parts.
6. Before working on truck, raise drive wheels free of floor or disconnect battery and use chocks or other positive truck positioning devices.
7. Before removing any component from the truck, make sure that the lifting mechanism (hoist) and slings are of the proper capacity and in good condition.
8. When working on hydraulic system, be sure the power is turned off, pallets are in lowered position and hydraulic pressure relieved in hoses and
9. When necessary to work with pallets above its lowered position, always place blocks beneath all elevated parts.
10. Brakes, steering mechanism, control mechanism and horn should be inspected daily and maintained in a safe operating condition.
11. All parts of lift mechanism and frame members should be carefully inspected daily and maintained in a safe operating condition.
12. All components of the hydraulic system should be inspected daily and maintained in a safe operating condition. Lift cylinder, valve and other similar parts should be checked to assure that "drift" has not developed that would exceed 1" per 5 minutes.
13. Sparkproof trucks and devices designed and approved for hazardous area operation should receive special attention to ensure that maintenance preserves the original, approved safe operating features.
14. Modifications and additions which affect capacity and safe truck operation should not be performed by the customer or user without the manufacturer's prior written approval. Capacity, operation and maintenance instruction plates, tags or decals should be changed accordingly.

**SERVICE INSTRUCTIONS**

15 Capacity, operation and maintenance instruction plates, tags and decals should be maintained in legible condition

16. The truck should be kept in a clean condition to minimize fire hazards and facilitate detection of loose or defective parts

17. Operation to check performance of the truck or attachments should be conducted in an authorized, safe clearance area

18. Always use Yale replacement parts to be sure they are interchangeable with the original parts and are of a quality equal to that provided In the original equipment

You should also be familiar with additional maintenance safety instructions contained in the following:

ANSI B56.1 - 1969 - Safety Standard For Powered Industrial Trucks.

This booklet can be obtained from:

Society of Mechanical Engineers  
345 East 47th Street  
New York, New York 10017

ANSI B56 2 - 1973 - (NFPA 500) Type Designations, Areas of Use, Maintenance and Operation of Powered Industrial Trucks.

This booklet can be obtained from:

National Fire Protection Association  
470 Atlantic Avenue  
Boston, Massachusetts 02210

Code of Federal Regulations Title 29, Chapter XVII, Section 1910 178 (OSHA) Powered Industrial Trucks.

This booklet can be obtained from:

Superintendent of Documents  
U.S. Government Printing Office  
Washington, D.C.20402

**HELPFUL HINTS TO REMEMBER WHILE MAINTAINING OR TROUBLE SHOOTING ELECTRICAL CIRCUITS**

1. Disconnect Battery when trouble shooting or checking out circuits with another source of power

2. Disconnect or isolate wires before checking out to eliminate sneak circuits.

3. Exercise caution when tightening wire connections making sure they are torqued properly for the size of nut or screw

4. Exercise caution when tightening motor leads to prevent turning of stud, thereby distorting or breaking internal motor connections.

5. Cover or prevent all oil from getting into motor when working on hydraulic components

6. Every 200 hours or monthly blow out drive motor with dry compressed air.

**WARNING - Make sure all covers have been properly replaced before putting truck in operation.**

7. Check all mechanical parts of contacts, including the springs for discoloration and loss of tension, the armature pivot points, over-travel of armature, the contactor pigtail, etc.

8. Remove as much as possible all dirt and debris before removal of drive motors

9. Mark or tag all wire leads prior to motor removal if truck has been functioning properly before failure, it will prevent mistakes on rewiring.

10. Cover all open gear cases after motor removal to prevent foreign matter from falling into gear train.

11. Always use a wiring diagram when troubleshooting is attempted. The diagram is your bible and will prevent many hours of needless trial and error work to save valuable time.

12. Always isolate the part of the control circuit that is giving the trouble and trace or check that area only, instead of the entire control circuit from beginning to end.

13. Take extra caution when installing new brushes, making sure they are properly seated (Refer to page 68) and all pigtails are connected without grounding out against steel components. Brushes should move freely in brush holders. Brush springs should have the proper tension 30 oz for pump motor, 38 oz. for drive motor.

14. Check the specific gravity of the battery using a hydrometer, making sure it does not read below 1.150, as this is considered a dead battery in Industrial truck application. A fully charged battery should read 1.275.

**ELECTRICAL SYSTEM**

15. If a grounded circuit is suspected in truck, start isolating the individual circuits, one at a time. First determine if in the primary (heavy leads) or secondary (control lead). If in the control circuit, start with forward and reverse circuit and isolate circuits by disconnecting main connections as you work down through the entire circuit.
16. Completely disconnect battery at the connector, because it is quite possible to pick up a current leak between battery and truck frame. Battery should be removed from the truck. The outside of the battery and the battery compartment should be washed down with a strong solution of baking soda to remove the electrolyte that has overflowed from time to time.

**ELECTRICAL SYSTEM DESCRIPTION:**

The drive electrical system consists of a butterfly switch located in the steer handle which is used to activate direction and speed contactors which directs various levels of battery current to the drive motor providing 2 speeds forward and 2 speeds reverse truck movement. The drive electrical system is protected by a 100 Amp fuse link. A hydraulic pressure switch, cutout relay and diode compose a circuit which maintains the 2 speeds forward and reverse under a load. This is accomplished by directing higher levels of current to the motor when the hydraulic pressure switch senses a load.

The lift and lower electrical system consists of a lift push button switch in the steer handle which activates the lift contactor which directs battery current to the hydraulic pump motor providing hydraulic oil pressure to raise the load pallets. It also contains a lower push button which activates a solenoid relief valve which releases hydraulic oil pressure in the system thereby lowering the load pallets. The lift electrical system is protected by a 200 amp fuse link.

**CONTACTOR ASSEMBLY**

The contactor assembly (fig. 5) is mounted on the top of the drive motor. The contactor assembly consists of the forward & reverse contactor (31), second (32) and third (33) speed contactors, cutout relay (11), resistor (4), fuse (26), terminal block (29) and horn (fig. 3 - Item 1). Overheating of the contactor assembly is controlled by thermostats (fig. 2 - Item 1) mounted in the contactor cover.

**REMOVAL**

- a. Disconnect battery.

- b. Remove two knobs (fig 1 - Item 2) and lift drive unit cover (fig 1 - Item 1) from truck.
- c. Tag and disconnect wires from thermostats on top of contactor cover (fig. 2 - Item 1). Remove (3) screws (fig. 2 - Item 2) securing cover to base and lift cover from contactor assembly. Remove "O" ring seal from groove in base.
- d. Tag and disconnect all wires necessary for removal of contactor assembly. This includes handle wires from terminal block (fig. 5 - Item 29), horn, switch connector, power wires at drive motor and wire at drive fuse (fig. 2 - Item 3).
- e. Remove screws and lockwashers securing contactor assembly base to top of drive motor.

**DISASSEMBLY**

- a. All components of the contactor assembly can be removed without removing the contactor assembly from the truck. Each component will be covered individually in the following paragraphs.

**INSTALLATION**

- a. Position contactor assembly on top of drive motor and install screws and lockwashers securing contactor base to motor.
- b. Connect all wires making sure they are connected to the same terminal from which they were removed. Make sure all connections are tight.
- c. Place "O" ring seal in groove in base, install contactor cover and secure with three screws. Connect wires to the thermostats on top of cover.

**WARNING** - Do not operate this truck with the cover removed.

- d. Install drive unit cover
- e. Connect battery.

**FORWARD & REVERSE CONTACTOR REMOVAL**

- a. Although it is not necessary, it is always good policy to remove the forward and reverse contactor assembly when any portion (other than the contact tips) are in need of repair. This will allow closer inspection of the various parts.
- b. Tag and disconnect all wires necessary for removal.
- c. Remove four screws, lockwashers and nuts securing contactor to base.

**ELECTRICAL SYSTEM**

**DISASSEMBLY**

(Refer to Fig. 4)

- a Remove screws, lockwashers (18) and (22) and stationary contacts (20).
- b. Remove screws, lockwashers (15) and shunts (13).
- c Remove screws and lockwashers (19) holding each armature retaining clamp to magnet frame (6). Remove clamps, armatures (24) and magnet core springs (11).
- d Remove round head screws, lockwashers (5), magnet cores (2), spring washers (14) and coils (16).
- e. Remove magnet frames (6) and stationary support (17) when cracked damaged or broken

**INSPECTION**

- a. Check the condition of each contact tip. In normal operation, the contacts will become blackened, discolored and roughened. This will not interfere with proper operation and cleaning is not necessary. The contacts should be replaced before the silver contact facing is completely eroded through to the backing material. It is recommended that contacts always be replaced in mating pairs. A new contact tip is 1/8" thick
- b The correct air-gap between contact tips is 5/16". When pressing armature contact all the way in, a slight wiping action will be observed between the two contact tips. This wiping action will prevent pitting, burning and welding of contact tips.
- c. Check all wires for fraying or cracking.
- d. Replace either coil (16) when it has an open circuit or when contactor does not pull in properly. (Be certain there is no mechanical bind or obstruction before replacing a coil.)

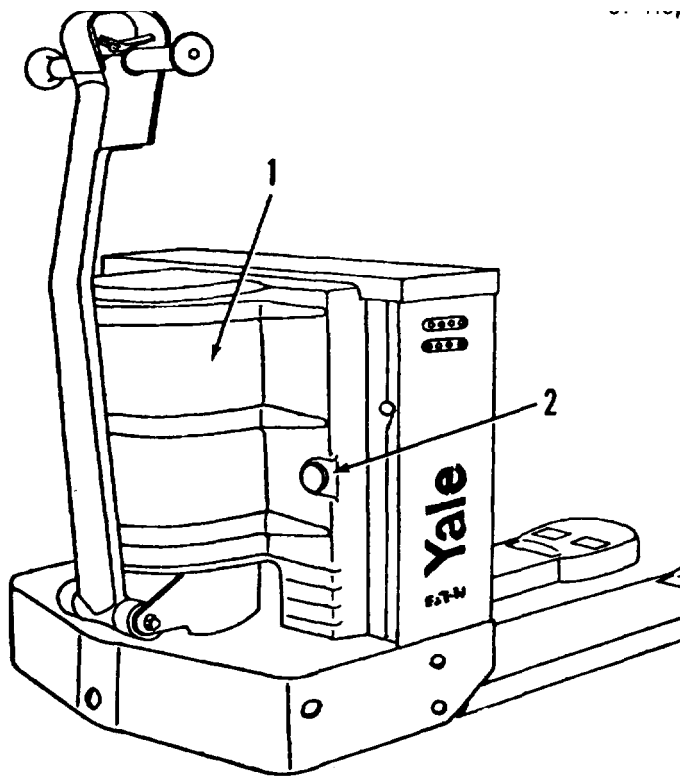

ITEM	DESCRIPTION
1	Drive Unit Cover
2	Knob

Figure 1 - General Truck

**ELECTRICAL SYSTEM****REPLACEMENT OF CONTACT TIPS WITH CONTACTOR MOUNTED IN TRUCK**

- a. Disconnect battery
- b. Remove drive unit cover and contactor assembly cover.
- c. Tag and remove necessary wires from contact tips.
- d. Remove screws and lockwashers (18) and (22) from stationary contacts. Remove stationary contacts (20).
- e. Remove cotter pins, cup washers and springs (12), screws and lockwashers (18) from moving contacts. Remove moving contacts (23).
- f. Reverse above to install new contact tips.

**REASSEMBLY**

- a. Install magnet frames (6) and stationary support (17).
- b. Install coil (16), spring washers (14), magnet cores (2), lockwashers and screws (5). Be certain coils are firmly seated on magnet frames.
- c. Assemble armature assemblies (24). Insert armature springs (11) in magnet core, install armatures, clamps, shunts, screws and lockwashers.
- d. Install stationary contacts (20) When pressing armature in, a slight wiping action will be observed between the two contact tips. This wiping action will help prevent burning, pitting and welding of contact tips. Be certain tips mate properly.

**INSTALLATION**

- a. Position contactor on contactor assembly.
- b. Install four screws, lockwashers and nuts securing contactor to base.
- c. Connect all wires making sure all connections are tight.

**2ND & 3RD SPEED CONTACTORS, HOIST CONTACTOR & CUTOUT RELAY**

- a. The 2nd speed contactor (fig. 5 - Item 32), 3rd speed contactor (fig. 5 - Item 33), hoist contactor (fig. 2 - Item 4) and cutout relay (fig. 5 - Item 11) are non-repairable items, and when found to be defective should be discarded and replaced with a new unit.
- b. To replace, disconnect battery, tag and remove wires from defective unit. Remove two mounting screws, washers and nuts.
- c. Reverse above to install a new unit.

**RESISTOR ASSEMBLY**

(Refer to Fig. 5)

- a. The resistor (4) is a non-repairable item and should be discarded when found to be defective and replaced with a new unit.
- b. To replace, disconnect battery, tag and remove wires from resistor taps. Remove nuts and lockwasher (3), bracket (23), and washers (24). Remove resistor from contactor assembly.
- c. Reverse above to install a new unit.

**POWER FUSES**

- a. The 100 amp drive circuit fuse (fig. 2 - Item 3) and the 200 amp lift circuit fuse (fig. 2 - Item 5) can be replaced as follows.
- b. Disconnect battery.
- c. Remove 4 screws securing fuse box cover. Remove cover.
- d. The fuse link have slots on each end for mounting, loosen both mounting screws and slide fuse link from terminals.

**CAUTION**

- e. When replacing a fuse link, make positively sure it is the correct amp rating or damage to the equipment could occur.

ELECTRICAL SYSTEM

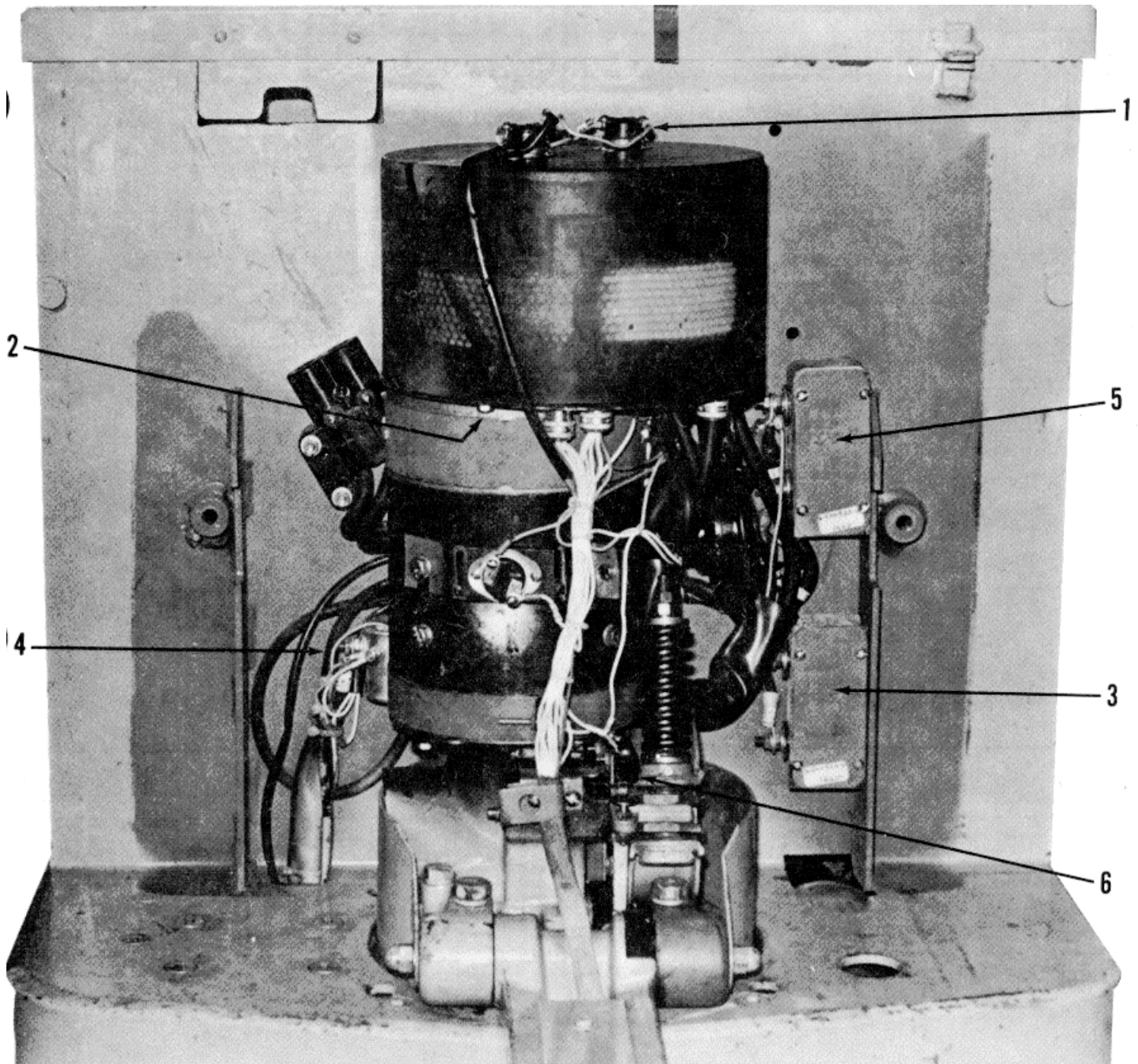

ITEM	DESCRIPTION
1	Thermostat
2	Hex Hd. Screw
3	Drive Fuse
4	Lift Contactor
5	Lift Fuse
6	Cut-Out Switch

Figure 2 - Electrical Accessories



**ITEM            DESCRIPTION**

- 1     Horn
- 2     Resistor Assembly
- 3     Contactor
- 4     Shunt
- 5     Terminal Block

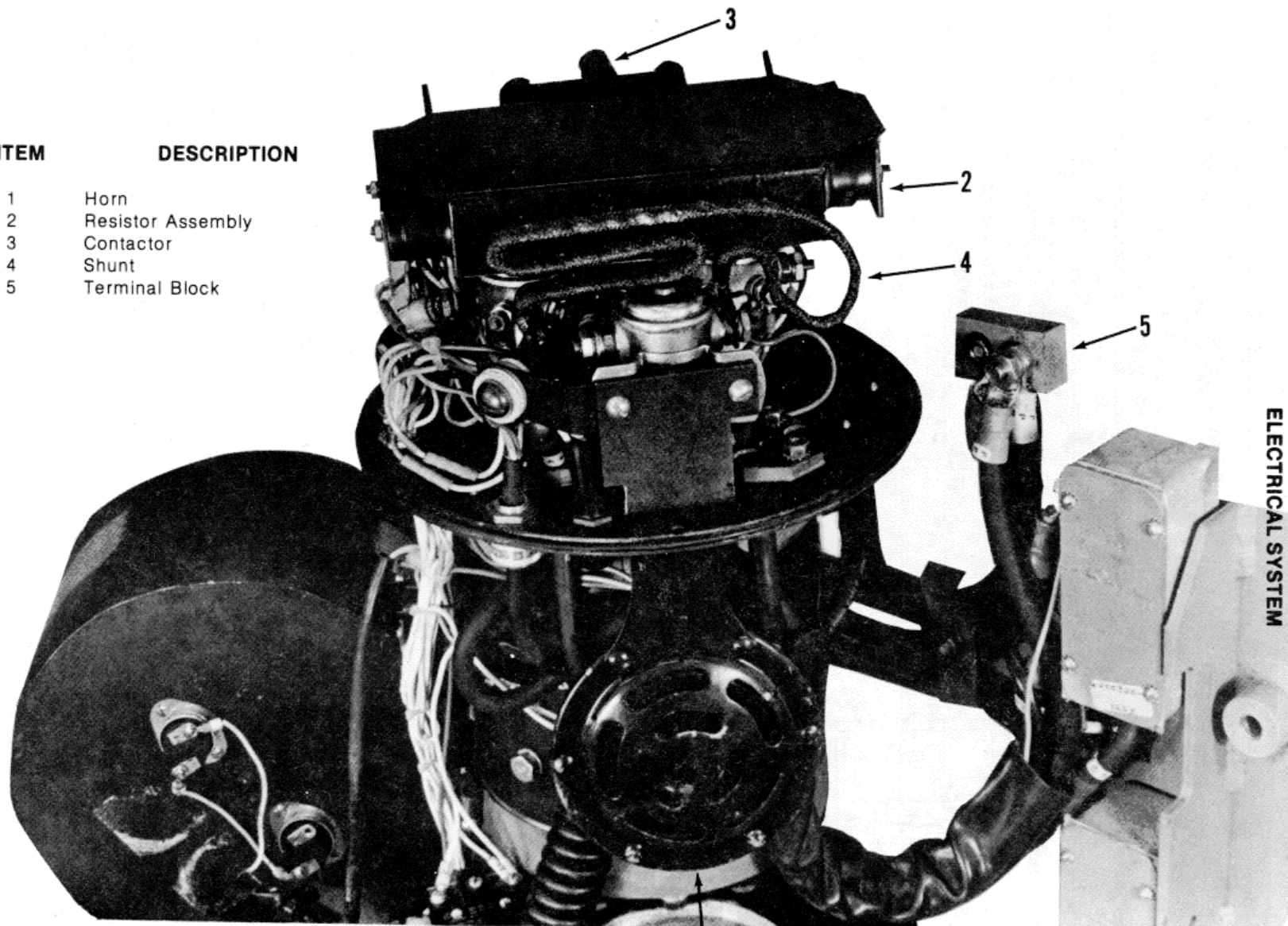
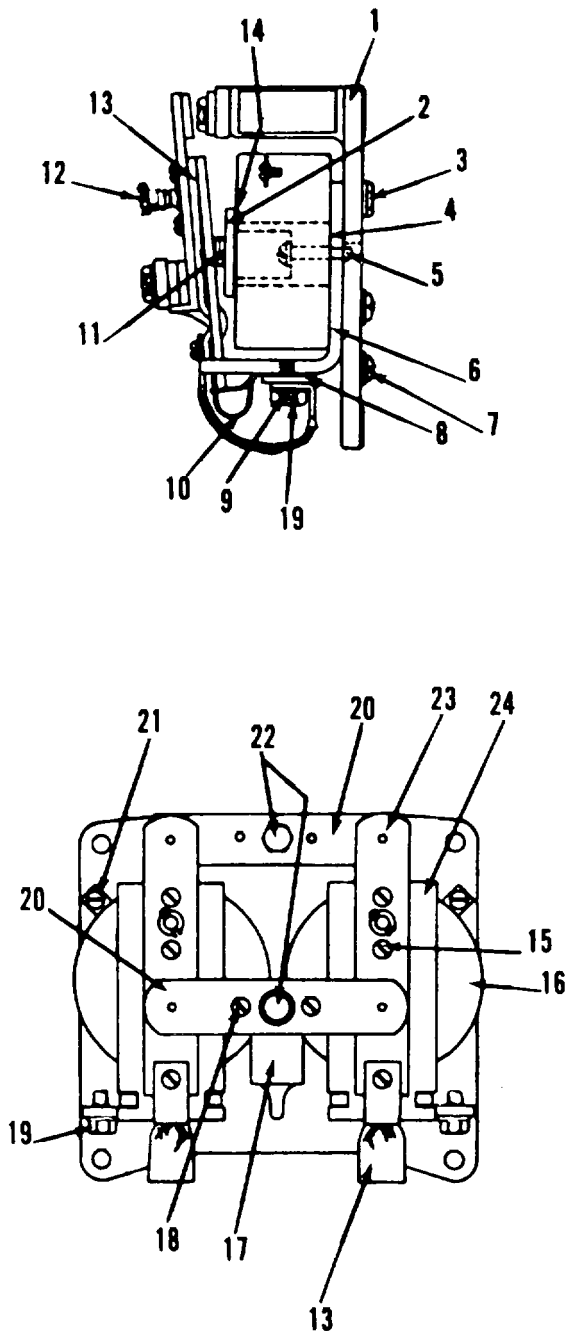

Figure 3 - Electrical System



ELECTRICAL SYSTEM



ITEM	DESCRIPTION
1	Base
2	Magnet Core
3	Flathead Screw
4	Flat Washer
5	Internal Tooth Shakeproof Lockwasher
6	Hex Nut
7	Magnet Core Shim
8	Brass Round Head Sems Screw
9	Magnet Frame
10	Round Head Sems Screw
11	Flat Washer
12	Connector
13	Round Head Sems Screw
14	Shunt Clamp
15	Spring
16	Cup Washer
17	Spring
18	Cotter Pin
19	Moving Contact Support and Shunt Assembly
20	Spring Washer
21	Fillister Head Sems Screw
22	Coil
23	Support
24	Fillister Head Sems Screw
25	Hexagon Head Sems Screw
26	Stationary Contact
27	Brass Binding Head Screw
28	Phillips Head Sems Screw
29	Moving Contact
30	Armature

Figure 4 - Forward and Reverse Contactor

ELECTRICAL SYSTEM

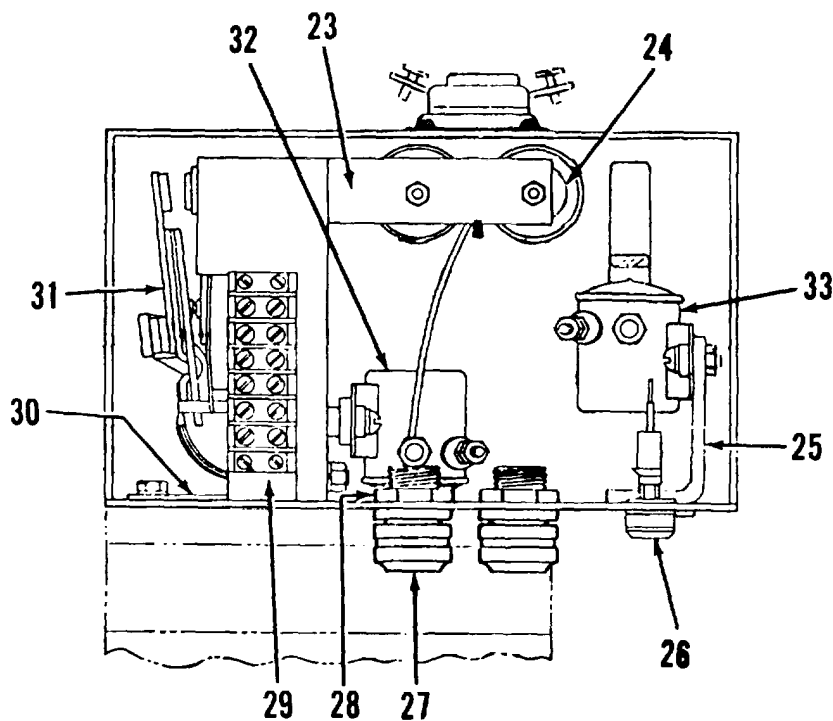
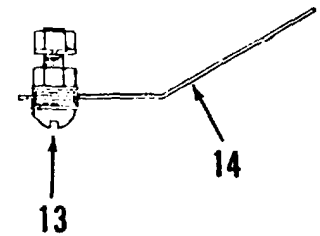
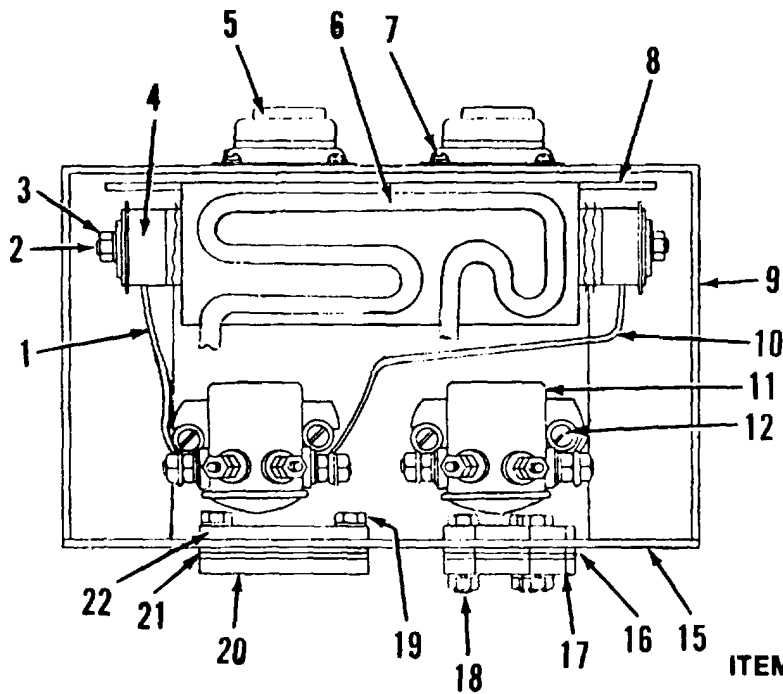

ITEM

DESCRIPTION

- 1 Connector
- 2 Threaded Rod
- 3 Hex Nut and Lockwasher
- 4 Resistor Assembly
- 5 Thermostat — 181 ° F
- 6 Shunt Resistor — .027 Ohms
- 7 Rd. Hd. Screw and Lockwasher
- 8 Heat Shield
- 9 Cover & "O" Ring
- 10 Connector
- 11 Cutout Relay
- 12 Rd. Hd. Screw and Lockwasher
- 13 Brass Rd. Hd. Screw
- 14 Bracket
- 15 Mounting Plate
- 16 Rubber Spacer
- 17 Spacer Plate
- 18 Rd. Hd. Screw, Nut, Lockwasher
- 19 Rd. Hd. Screw and Lockwasher
- 20 Threaded Plate
- 21 Rubber Spacer
- 22 Plate
- 23 Bracket
- 24
- 25
- 26
- 27
- 28
- 29
- 30
- 31
- 32
- 33

Figure 5 - Contactor Assembly

**ELECTRICAL SYSTEM****Figure 5 - Contactor Assembly**

24	Reducer Washer
25	Bracket
26	Fuse Post and 15 Amp Fuse
27	Sparkproof Connector - Rubber Grommet
28	Electrical Conduit Nut
29	Terminal Block
30	Insulator - For Contactor
31	Forward and Reversing Contactor Assembly
32	Second Speed Contactor
33	Third Speed Contactor

**TROUBLESHOOTING**

When trouble shooting any electrical circuit be certain of the area of trouble before doing any work on the circuit For instance, if the first speed direction contactors are not pulling in, you would not start checking the heavy power leads to motor or handle controller, but would check the control circuit or light small wires at contactor and butterfly control switch If, however, the coil is being energized and contactor is pulling in, but we are not getting first speed operation, then the difficulty must be in the power circuit. Check power leads, contact strips, resistors, contact bars, contact tips or motor. It is much easier to trouble shoot when you isolate the area of trouble Amount of down time consumed will be much less and truck will be back in operation much sooner

**DRIVE**

<b>TROUBLE</b>	<b>CAUSE</b>	<b>REMEDY</b>
Forward or reverse contactors not pulling in.	Open 15 amp fuse.	Replace fuse.
	Defective thermostat.	Replace thermostat.
	Defective lock switch.	Replace switch.
	Defective cut-out switch.	Replace switch.
	Broken wire at controller directional switch.	Repair or replace.
	Directional spring tips in steer handle switch not making contact.	Replace switch.
	Battery not connected.	Insert plug.
Contactors pulling in, but truck does not run in one direction.	Contact tip does not make contact or N C tip welded shut	Tighten magnet core screw. Remove obstruction. Replace tips.
	Loose or broken power lead (wire) at the contactor.	Tighten or replace.
Contactors pulling in but truck does not run (first speed) in either direction.	Brake too tight.	Adjust brakes.

**ELECTRICAL SYSTEM**

<b>TROUBLE</b>	<b>TROUBLE SHOOTING CAUSE</b>	<b>REMEDY</b>
Contractors pulling In but truck does not run (first speed) in either direction	Replace fuse.	Tighten or replace.
	Broken resistor	Replace.
Contractors pull In but truck does not run all speeds in either direction	Open 100 amp fuse	Replace fuse.
	Broken wire at motor	Repair or replace
	Brushes too short	Replace and make necessary adjustments
	Open field circuit In drive motor.	Repair or replace. Occasionally truck will run unless dead spot of commutator stops beneath brushes.
	Broken wire at main power supply of handle controller.	Repair or replace
Truck travels too fast unloaded.	Hydraulic switch shorted	Test hydraulic switch and replace if necessary. (Switch contacts should close between 490 and 510 PSI.
Truck has only 1st speed when loaded.	Diode shorted Hydraulic switch open	Replace diode.. Test hydraulic switch and replace if necessary (Switch contacts should close between 490 and 510 PSI
Truck has 2nd speed only, loaded	Cut-out relay open.	Replace cut-out relay.

**HOIST**

<b>TROUBLE</b>	<b>CAUSE</b>	<b>REMEDY</b>
Motor does not operate when hoist push-button is pressed in	Open 200 amp fuse.	Replace fuse.
	Push button not operating properly.	Check and replace when defective.
	Contractor does not pull in.	Check and replace when defective.
	Brushes too short.	Replace and make necessary adjustments.
	Open field or armature circuit in pump motor.	Repair or replace.
	Broken wire at terminal stud Assembly	Repairer replace.
	Battery not connected.	Insert plug.

ELECTRICAL SYSTEM

DIAGRAM

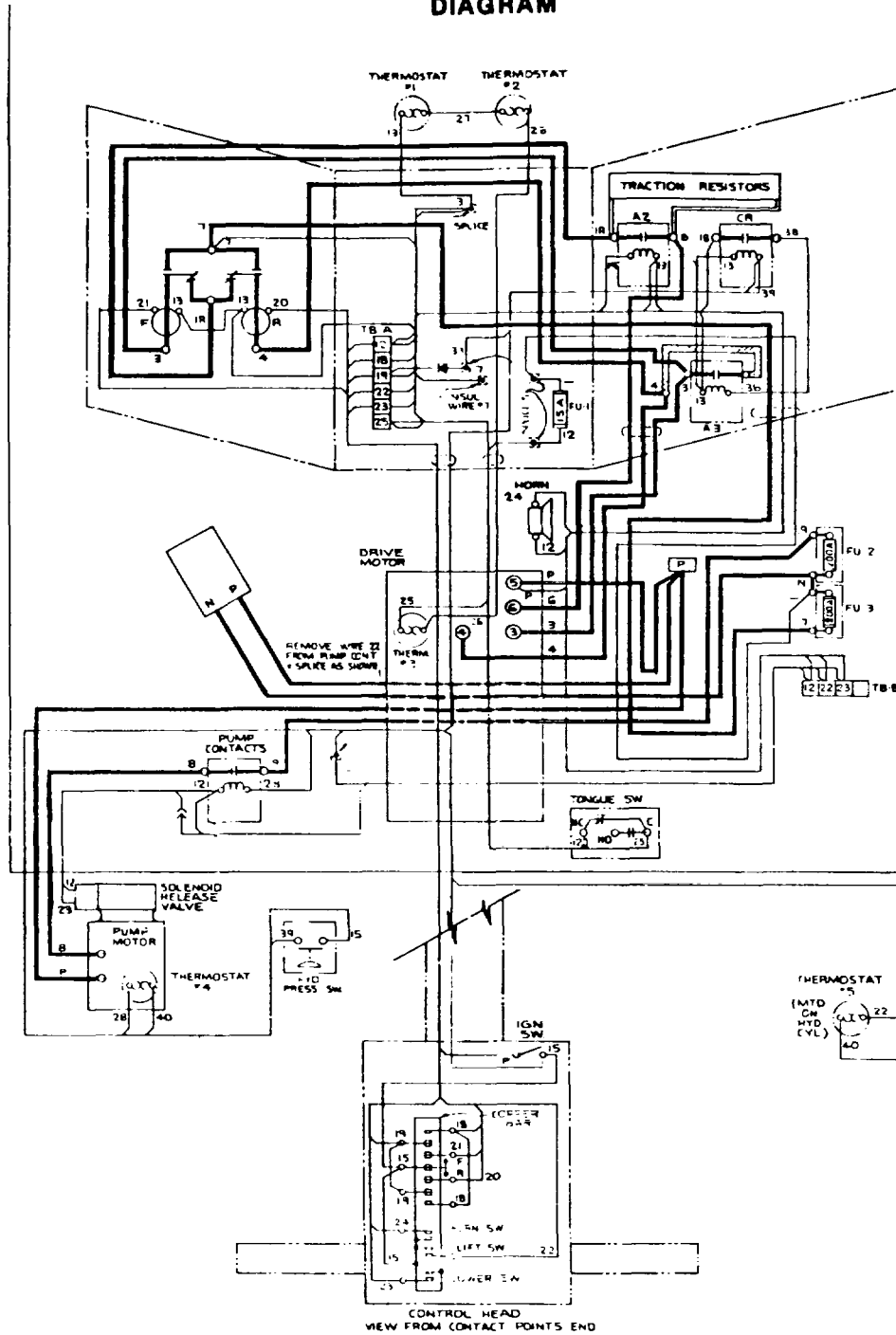

Figure 6 - Wiring Diagram (5028667-01)

ELECTRICAL SYSTEM  
SCHEMATIC

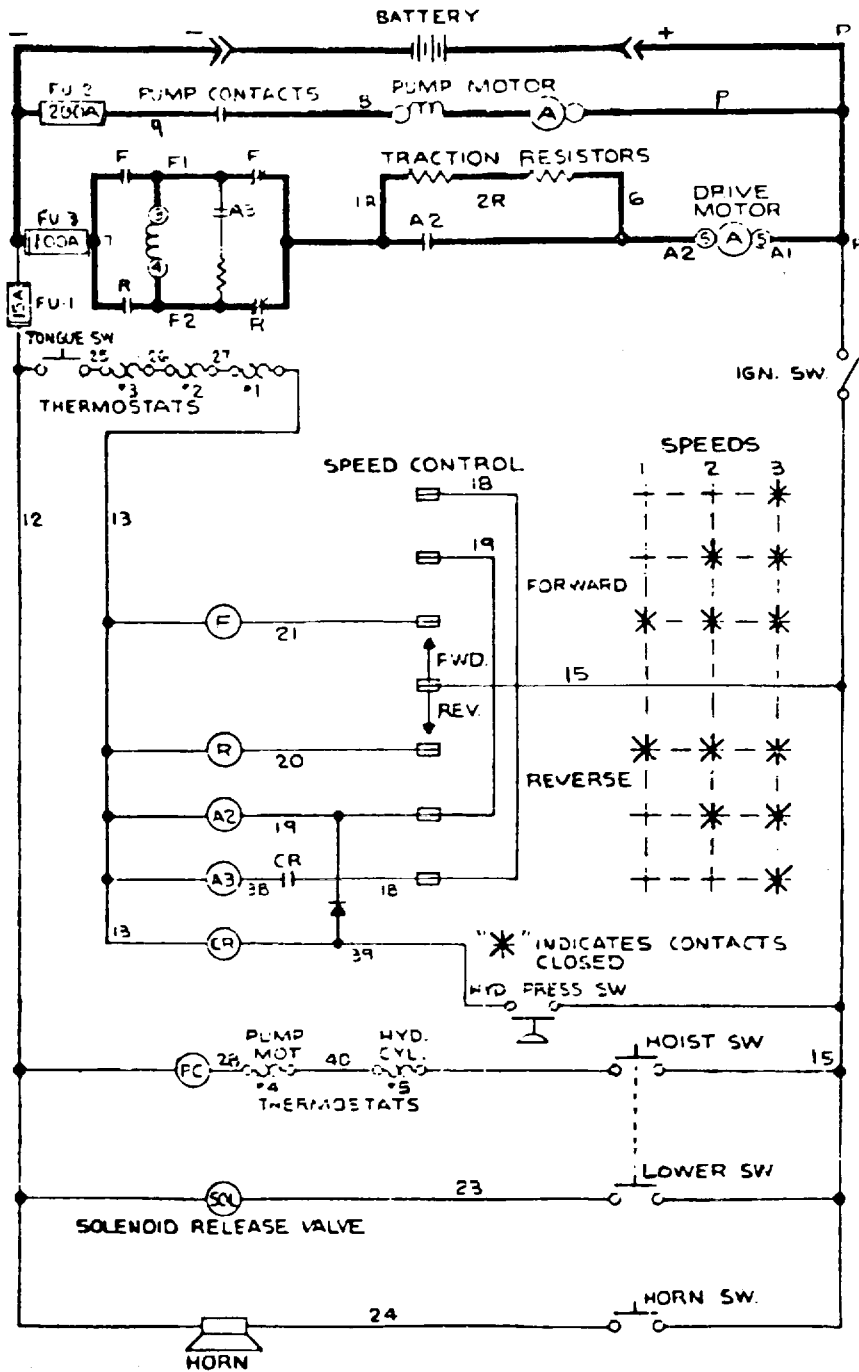
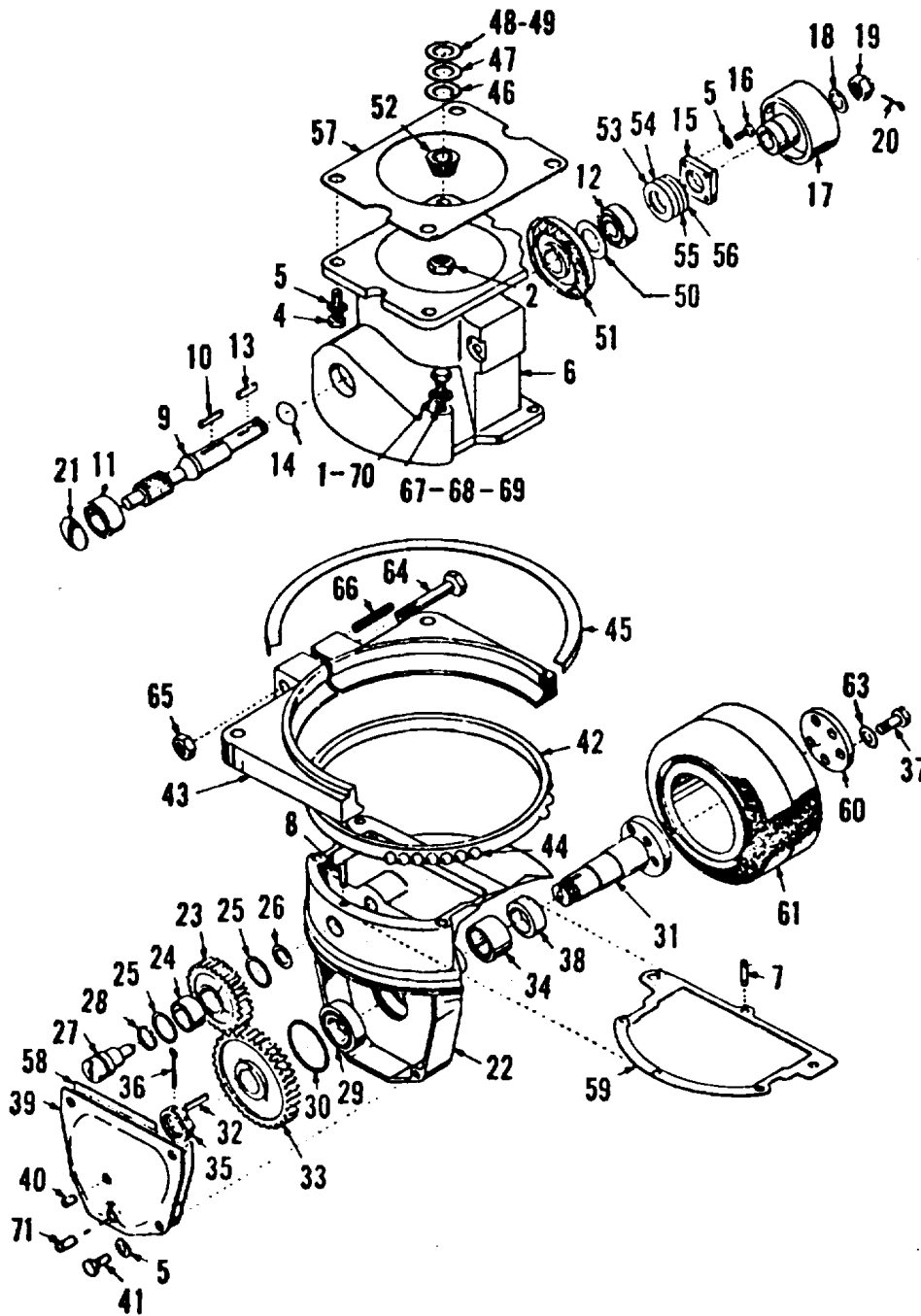

Figure 6 - Wiring Diagram (6028167-01)

DRIVE UNIT ASSEMBLY



ITEM	DESCRIPTION
1	Lockwasher
2	Locknut
3	Not Used
4	Cap Screw
5	Lockwasher
6	Housing - Upper
7	Pin
8	Pin
9	Shaft
10	Key
11	Bearing
12	Bearing
13	Key
14	"O" Ring
15	Retainer
16	Cap Screw
17	Brake Drum
18	Washer
19	Nut
20	Cotter Pin
21	Plug
22	Housing - Lower
23	Gear
24	Bearing
25	Ring
26	Spacer
27	Shaft
28	"O" Ring
29	Bearing
30	Ring
31	Shaft
32	Key
33	Gear
34	Bearing
35	Nut
36	Cotter Pin
37	Bolt
38	Oil Seal
39	Cover
40	Plug
41	Cap Screw
42	Race - Inner
43	Race - Outer
44	Ball
45	Shield
46	Shim
47	Shim
48	Shim
49	Shim
50	Shim
51	Gear
52	Pinion

Figure 7 - Drive Unit Assembly

**DRIVE UNIT ASSEMBLY**

**Figure 7 - Drive Unit Assembly**

ITEM	DESCRIPTION
53	Shim
54	Shim
55	Shim
56	Shim
57	Gasket
58	Gasket
59	Gasket
60	Plate
61	Wheel Assembly
63	Washer
64	Screw
65	Locknut
66	Set screw
67	Hex Screw
68	Hex Screw
69	S H. Screw
70	Lockwasher
71	Plug - Drain
72	Lube Fitting

**REMOVE AND INSTALL CONTACTOR ASSEMBLY**

- a. Disconnect battery.
- b. Remove drive unit cover retaining knobs (fig. 1).
- c. Remove drive unit cover (fig 1).
- d. Remove three hex hd. screws retaining contractor assembly cover and remove cover (fig. 2).
- e. Disconnect, tag and remove all wires necessary for removal of control panel. This will include handle wires at terminal block, horn and cutout switch connector. Motor leads, two wires at junction block and two wires at terminal block on battery front plate.
- f. Remove four nuts and lockwashers securing contactor assembly to drive motor.
- g. Remove contractor assembly (fig. 5).

**WARNING** - Make certain contractor assembly cover and seal are installed before operating truck.

- h. Reverse above to install

**REMOVE AND REPLACE DRIVE WHEEL**

Refer to Figure 7

- a. Disconnect battery by pulling connector out of plug.
- b. Raise and block truck high enough to remove drive wheel.
- c. Remove screw (37), lockwasher (36), and clamp plate (60) securing wheel to axle.
- d. Remove wheel (61).
- e. Reverse above to Install. Tighten screws, torque screws to 140 to 160 ft. lbs. dry.

**REMOVE AND INSTALL DRIVE MOTOR**

- a. Disconnect battery.
- b. Remove drive unit cover (fig. 1).
- c. Remove and tag motor wires to facilitate assembly.
- d. Remove four screws and lockwashers securing motor to drive unit housing. Remove motor. Place a clean cloth over drive unit opening.
- e. Reverse above to Install. Place motor in same position as removed.

**REPLACE DRIVE MOTOR BRUSHES**

- a. Disconnect battery
- b. Remove drive unit cover (fig.1).
- c. Remove motor enclosure cover. Brushes are now accessible. Replace brushes. Refer to instructions for fitting brushes. It may be necessary to turn drive unit to remove rear brushes.
- d. Reverse above to install.



**DRIVE UNIT ASSEMBLY****REMOVAL OF COMPLETE DRIVE UNIT**

- a. Disconnect and remove battery from truck.
- b. Remove drive unit cover (fig. 1 Item 1).
- c. Remove contractor assembly (Refer to paragraph on Contractor Assembly Removal).
- d. When an overhead hoist is available, remove steer handle (Refer to paragraph on Steer Handle Removal), drain oil from drive unit. Turn truck upside down with overhead hoist, place blocks under each end of truck to keep it level.
- e. When an overhead hoist is not available, using handle as a fulcrum or balance lever, turn truck on its side. Remove steer handle (Refer to paragraph on Steer Handle Removal).
- f. Remove four locknuts and screws (fig. 16 Item 1) securing drive unit to frame.
- g. When an overhead hoist is not available, it will be necessary to get another person to help slide the drive unit out of the frame. Truck will remain on its side during this procedure.
- h. When an overhead hoist is available, place a sling around drive wheel assembly and attach sling to overhead hoist. Lift drive unit out of frame. Truck will remain upside down during this procedure.

**DISASSEMBLY**

- a. Refer to fig. 7 for location of parts.
- b. Move drive unit to a clean work area.

**WARNING** --The drive unit could contain asbestos dust from the brake linings. If using compressed air for cleaning always wear a mask or filter.

- c. Before disassembling drive unit, wash and thoroughly clean the outside of the drive unit. Do not allow cleaning fluid to get in drive motor or brake linings. Blow dry with an air hose when compressed air is available. Place drive unit on a bench or stand and securely block in an upright position. Remove drain plug (71) and drain oil in a pan if not already done. Replace plug.

**REMOVE DRIVE MOTOR**

- a. Remove four screws (4) and lockwashers (5) securing drive motor to drive unit housing. Remove drive motor. It may be necessary to place a sling around motor, attach to an

overhead hoist and lift motor out of unit. Place a clean cloth over drive unit opening.

**REMOVE BRAKE SHOES**

- a. Refer to fig. 9 for location of parts.
- b. Remove retaining rings (8) and link (7) from shoe pivot pins (6).
- c. Remove nuts (1), spring seats (2) and spring (3). Remove rod (17).
- d. Remove brake shoes (4).
- e. Loosen set screws (10) and remove adjusting screws (5) when shoes (4) are to be replaced.
- f. Remove retaining ring (16) and brake release arm (15) when release arm sticks or needs replacement.

**REMOVE BRAKE DRUM, SPIRAL BEVEL GEAR AND PINION SHAFT**

- a. Refer to fig. 7 for location of parts.
- b. Remove cotter pin (20), nut (19) and using a suitable puller remove brake drum (17). Remove key (13).
- c. Remove four screws (16), lockwashers (5), retainer (15) and shims (53-56).
- d. Using a plastic hammer, tap threaded end of pinion shaft (9) out opposite end far enough to remove expansion plug (21), bearing (12), shims (49-50) and gear (51).
- e. Remove key (10), shaft (9), bearing (11) and "O" ring (14).

**REMOVE UPPER HOUSING**

- a. Refer to fig. 7 for location of parts.
- b. Remove four screws (67) and lockwashers (70) securing upper (6) and lower (22) housings.
- c. Separate and remove upper housing.

**REMOVE INTERMEDIATE GEAR ASSEMBLY**

- a. Refer to fig. 7 for location of parts.
- b. Remove dowel pins (7) & (8).
- c. Remove intermediate gear shaft (27), intermediate gear (23) and spacer (26).
- d. Remove and discard "O" ring (28).

**DRIVE UNIT ASSEMBLY**

- e. Remove one retaining ring (25) and bearing (24) from intermediate gear (23).

**REMOVE AXLE SHAFT ASSEMBLY**

- a. Refer to fig. 7 for location of parts.
- b. Remove four screws (41) and lockwashers (5) securing cover (39) to lower housing (22). Remove cover (39) and gasket (58).
- c. Remove five bolts (37) and lockwashers (63).  
Remove clamp plate (60) and wheel (61).
- d. Remove cotter pin (36) and nut (35) from axle shaft (31).
- e. Using a brass bar, tap axle shaft (31) out of drive gear (33) and bearings (29) & (34). Remove shaft (31).
- f. Remove drive gear (33) and key (32).
- g. Remove retaining ring (30) and Inner bearing (29).
- h. Remove oil seal (38) and outer bearing (34).

**NOTE :** Refer to page 67 for the procedure for checking the ring bearing.

**REMOVE RING BEARING ASSEMBLY**

- a Refer to fig. 7 for location of parts.
- b Remove bearing shield (45).
- c Remove locknut (65) and screw (64) from outer bearing race (43).
- d. Do not disturb adjusting screw (66) setting at this time.
- e. Spread outer bearing race (43). Remove inner bearing race (42) and all 72 balls (44).

**REASSEMBLY**

- a. Before starting to reassemble the drive unit assembly wash and thoroughly clean all parts in a suitable solvent and dry. Make sure all gasket material is removed from housings and covers and that mating surfaces are smooth.
- b. Check housings for cracks. Check housing bores for damage, especially around snap ring grooves. Check all threaded holes for damage.
- c. Check all bearings for excess wear and flat spots. Dip clean bearings in new clean drive unit

oil and wrap in a clean lint free cloth until ready to use.

- d. Check all gears for excess wear, damaged teeth and keyways. Check keys for rounded edges and cracks. Check key fit in the proper shaft keyway and if fit is loose replace key or/and shaft e. Check all shafts for excess wear and damaged keyways. Check keys for rounded edges and cracks. Check key fit in the proper shaft keyway and if fit is loose replace key or/and shaft f. Replace all worn or damaged parts. When reassembling use new gaskets, "O" rings and oil seals.

**INSTALL RING BEARING ASSEMBLY**

- a. Refer to figure 7 for location of parts
- b. Install inner race (42) on lower housing (22).
- c. Install outer race (43) around inner race and spread just enough to drop the bearing balls (44) in between the races. Be sure that 72 balls are installed
- d. Install bolt (64) and locknut (65) in outer race. Do not overtighten.
- e. Final adjustment of the ring bearing can not be till the drive unit is mounted in the truck frame.

**INSTALL AXLE SHAFT**

- a. Refer to fig. 7 for location of parts.
- b. Install outer bearing (34) and new oil seal (38), apply a light coating of clean oil to I.D. of oil seal.
- c. Install inner bearing (29) and retaining ring (30).
- d. Insert key (32) in drive gear (33), position drive gear in housing.
- e. Carefully insert axle (31) through oil seal (38), outer bearing (34) and inner bearing (29) Align keyway in shaft with key and tap axle in place.
- f. Install and tighten nut (35) lining up a slot in the nut with a cotter pin hole in the shaft. Install a new cotter pin (36) and spread.
- g. Using a new gasket (58) install cover (39) on lower housing using screws (41) and lockwashers (5).
- h. Mount wheel (61) on axle (31) and secure in place with clamp plate (60), washers (63) and bolts (37). Torque bolts to 140-160 ft. lbs. dry.

DRIVE UNIT ASSEMBLY

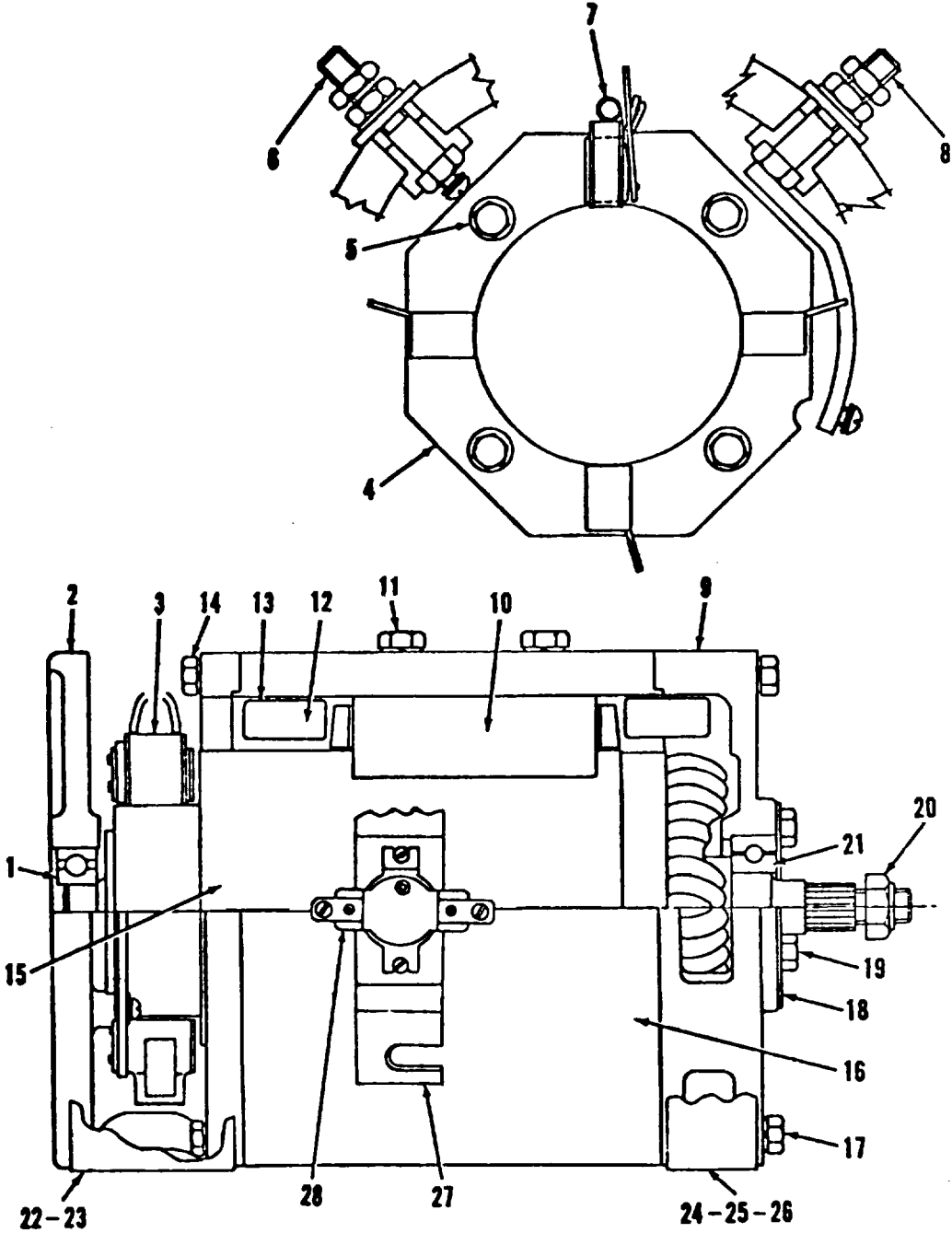

Figure 8 - Drive Motor

**DRIVE UNIT ASSEMBLY**

<b>ITEM</b>	<b>DESCRIPTION</b>	
1	Bearing	a. Refer to paragraph on Gear Adjustment before proceeding with this installation.
2	Commutator End Head	b. Refer to fig. 7 for location of parts.
3	Brush Set	
4	Brush Holder Assembly	c. Apply a light coating of vaseline to a new "O" ring (14) and install in groove on shaft (9).
5	Hex Screw Flat Washer Lockwasher	d. Install bearing (11) on pinion end of shaft (9)
6	Terminal Screw	e. Insert key (10) in shaft (9)
7	Brush Spring	
8	Terminal Assembly	f. Position spiral bevel gear (51) in housing Insert shaft (9) with bearing through bearing bore in housing and through gear, lining up keyway in gear with key Tap bearing (11) into housing being certain gear bottoms on shaft shoulders.
9	Drive End Head	
10	Pole Piece	
11	Hex Screw Lockwasher	g. Install inner shims (49-50), ball bearing (12), and outer shims (53-56)
12	Field Coil	
13	Insulator	
14	Hex Screw Lockwasher	h. Install bearing retainer (15) using four screws (16) and lockwashers (5).
15	Armature Assembly	
16	Motor Frame	
17	Hex Screw Lockwasher	i. Insert key (13) in shaft and install brake drum (17) lining up keyway with key. Install nut (19) and cotter pin (20).
18	Bearing Retainer	
19	Self-Locking Screw	
20	Elastic Stop Nut	
21	Bearing	j. Install a new plug (21) In housing bearing bore.
22	Enclosed Commutator Cover	
23	Hex Screw Lockwasher	
24	Enclosed Drive End Cover	
25	Pin	
26	Rd Hd Screw Square Nut	
27	Bracket	
28	Thermostat	

**INSTALL DRIVE MOTOR**

**INSTALL INTERMEDIATE GEAR**

- a. Refer to fig 7 for location of parts
- b. Apply a light coating of vaseoline to a new "O" ring (28) and install on shaft (27)
- c. Install bearing (24) in intermediate gear (23) Install retaining rings (25) in gear.
- d. Position spacer (26) and gear (23) in housing (22), insert and tap shaft (27) in place Turn shaft to align dowel pin holes, install both dowel pins (7), and (8) in housing (22) to secure shaft.

**INSTALL PINION SHAFT, SPIRAL BEVEL GEAR AND BRAKE DRUM**

**INSTALL UPPER HOUSING**

- a. Refer to fig. 7 for location of parts.
- b. Install a new gasket (59) on lower housing.
- c. Position upper housing and motor over lower housing Be certain dowel pin holes are properly aligned.

**DRIVE UNIT ASSEMBLY**

- d. Install screws and lockwashers (67-69), tighten screws
- e. Rotate armature to be sure gears turn freely.
- f. Check to see if drain plug (71) is in cover and oil level plug (40) is removed. Remove breather plug from upper housing. Consult lubrication section and add oil through filler hole until it starts to flow from oil level hole. Install and tighten both oil level and breather plugs.
- g. Whenever possible test unit before installing in truck. Make necessary adjustments.
- h. If truck has been turned completely over (not on its side) it will be necessary to drain the oil before installing the unit in the truck.
- d. When an overhead hoist is available, raise truck high enough to remove blocks. Remove blocks, then lower truck onto its wheels, install steer handle.
- e. When an overhead hoist is not available, install steer handle using handle as a fulcrum or balance lever turn truck onto its wheels.
- f. Install contractor assembly (Refer to paragraph on Contractor Assembly Installation)
- g. Adjust drive unit ring bearing (Refer to paragraph on Ring Bearing Adjustment).
- h. Adjust brakes (Refer to paragraph on Brake Adjustment)
- i. Adjust cut-out switch (Refer to paragraph on Cut Out Switch Adjustment).
- j. Install drive unit cover.
- k. Install and connect battery.
- l. Check operation of truck. Run truck in all speeds, in both directions, with and without a load. Make necessary adjustments

**INSTALL BRAKE ASSEMBLY**

- a. Refer to fig 9 for location of parts
- b. Install brake release arm (15) and retaining ring (16)
- c. Install adjusting screws (5) if they were removed. Install set screws (10) but do not tighten till brakes are adjusted
- d. Install brake shoes (4)
- e. Install spring (3), spring seats (2), rod (17) and nuts (1).
- f. Install link (7) on pivot pins (6) and install retaining rings (8)
- h. Steer handle must be installed before brakes can be adjusted

**INSTALL COMPLETE DRIVE UNIT**

- a. If an overhead hoist is not available it will be necessary to get another person to help slide drive unit into position. Truck will be on its side
- b. When an overhead hoist is available, place a sling around drive wheel and attach sling to overhead hoist. Lift drive unit high enough to clear frame, position, then lower into place
- c. Install four screws (fig 16 Item 1), lockwashers and nuts securing drive unit to frame. Tighten nuts.

**BRAKE ADJUSTMENT**

- a. Refer to fig 9 for location of parts
- b. To adjust brake, the control handle must be in its vertical position. Back off approximately two full turns on the two set screws (10) located on the front of the brake shoes. Turn the two brake cam adjusting screws (5) either to or away from the brake release arm to a clearance of 1/64" to 1/32". Retighten the two set screws (10).

**CUT-OUT SWITCH ADJUSTMENT**

- a. The cut-out switch (fig 2 Item 6) and brake assembly are synchronized allowing truck to move only when handle is in driving position. Brake must be on (applied) when handle is all the way up or all the way down. This safety feature helps prevent injury to operator, truck or load. Therefore cut-out switch must be properly adjusted
- b. Disconnect battery.
- c. Remove drive unit cover (fig 1 Item 1)

DRIVE UNIT ASSEMBLY

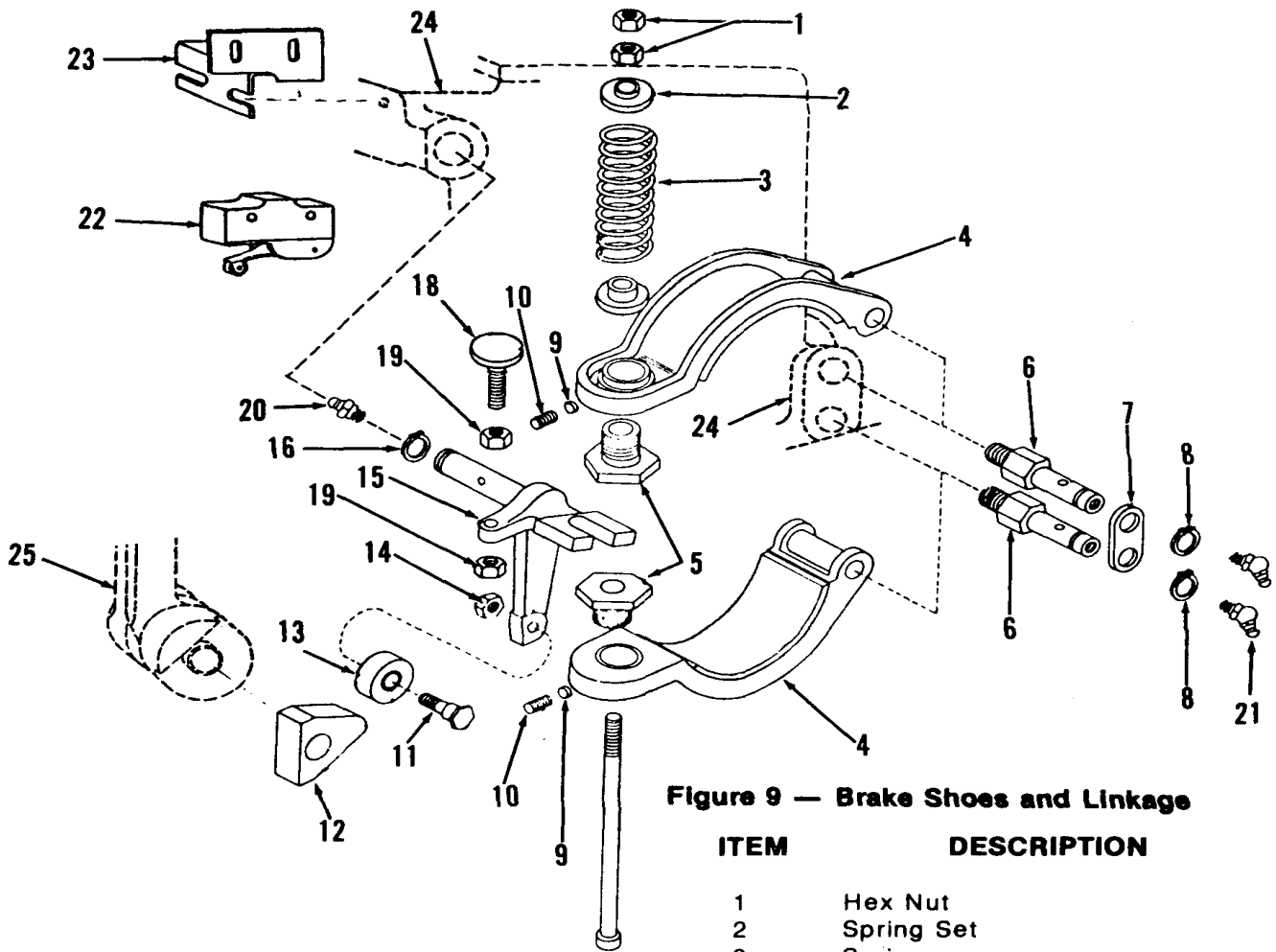

Figure 9 — Brake Shoes and Linkage

ITEM	DESCRIPTION
1	Hex Nut
2	Spring Set
3	Spring
4	Brake Shoe
5	Adjusting Screw
6	Pivot Pin
7	Link
8	Retaining Ring
9	Setscrew Seat
10	Setscrew
11	Stud
12	Brake Cam
13	Roller
14	Stop Nut
15	Brake Release Arm
16	Retaining Ring
17	Rod
18	Switch Actuator
19	Hex Nut
20	Lube Fitting — Brake Shoe Pivots
21	Lube Fitting — Brake Arm Pivot
22	Cut-Off Switch
23	Switch Mounting Bracket
24	Reference — Drive Unit Housing
25	Reference — Steer Handle

- d. Place handle in vertical position (up against drive unit). Brake is in on position and power cut off switch should be open. Slowly pull handle down until switch clicks (makes contact). Brake should release just before this click is heard. Adjust switch actuator (fig. 9 Item 18) when necessary. Return handle to vertical position. Power cut-off switch button must not bottom. Button should have 1/16" to 1/8" additional travel with brake on. Check by placing a gauge under button with brake applied.
- e. Check above with handle all the way down. Brake must be on with handle all the way down or all the way up. Slowly raise handle until switch clicks (makes contact). Brake must release just before click is heard.
- f. battery. Check operation.

**DRIVE UNIT ASSEMBLY**

**GEAR ADJUSTMENT**

(When Original Gears Are Reinstalled)

- a. Assemble drive unit as shown in Drive Unit Reassembly and Installation paragraph. Insert a small amount of grease in unit to protect gears.
- b. When original gears are being installed it is necessary to use the original shims at motor and shims at retainer Gears that have been in service for long periods form running contacts, therefore gear lash can only be reduced to a point of smooth rotation of gears
- c. Position original shims and install motor with socket head screws. Original shims have already been installed between housing cover and retainer
- d. Turn armature to check backlash Smoothness or roughness may be felt by rotating armature If a slight overlap takes place, rotation will be rough and an additional shim will be necessary at retainer.
- e. Be certain drive unit has been filled with SAE 90EP GEAR OIL to proper level

**GEAR ADJUSTMENT**

(When New Gears Have Been Installed)

**Step 1. Pinion Setting**

- a. Assembly drive unit as shown in Drive Unit Reassembly and Installation paragraph Be certain bearings have been lubricated before installation
- b. Record the dimension etched on head of old pinion. This dimension represents the distance from face of pinion to center of spiral bevel gear shaft.
- c. Compare the dimensions of the old and new pinions Add or subtract the dimensions on the old pinion from that of the new pinion.

Example:

Old Dimension	1.698"
New Dimension	<u>1.693"</u>
	.005"

Use old shim pack plus and additional .005" shim or	
Old Dimension	1.698"
New Dimension	<u>1.703"</u>
	-.005"

Use old shim pack minus a .005" shim.

**NOTE--** When the upper housing has been replaced gear adjustment must be made starting with Step 2.

**Step 2. Tooth**

Having replaced pinion and spiral bevel gear with new gears and proper shims as outlined above, proceed to adjust tooth contact as follows:

- a. Lightly apply oiled red lead to eight or nine spiral bevel gear teeth.
- b. Position shims and install motor with socket head screws. Original shims have already been Installed between housing cover and retainer
- c. Apply a small amount of resistance to drive wheel and rotate armature with a wrench. In rotating the gears the red lead will be squeezed away from the areas whose size, shape and location indicate the extent of tooth contact When making adjustments check both sides of the gear teeth. Remove or add shims at motor and retainer as necessary to obtain correct tooth contact Correct tooth contact will also give proper backlash of .003" to .005" inch

**d. Note the nature of tooth contact as shown In sketches of figure 10. Make necessary adjustments to obtain correct tooth contact as shown In sketch "A "**

- 1. "A" indicates proper contact
- 2. "B" indicates a high narrow contact Remove a shim at motor and one at retainer.
- 3. "C" indicates a short heel contact Add a shim at motor and remove one at retainer
- 4. "D" Indicates a low narrow contact Add a shim at motor and remove one at retainer
- 5. "E" indicates a short toe contact Remove a shim at motor and add a shim at retainer

e. Install shims, motor, lockwashers and socket head screws Be certain drive unit has been filled with SAE 90 Gear Oil to proper level after above adjustments have been made

**Drive Unit Ring Bearing Adjustment**

**The following procedure Is recommended when adjusting ring bearing to obtain proper ease of steering:**

- 1. Raise and block drive unit end of truck so that drive is off the floor.

DRIVE UNIT ASSEMBLY  
DRIVE UNIT ASSEMBLY

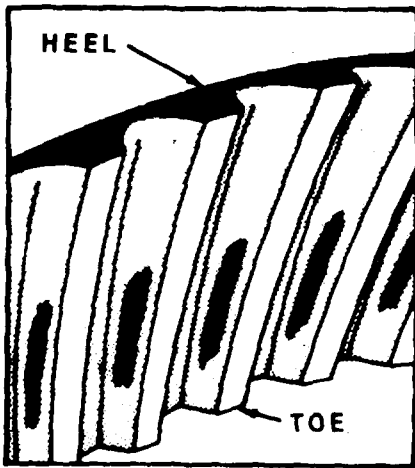

FIGURE-A CORRECT CONTACT

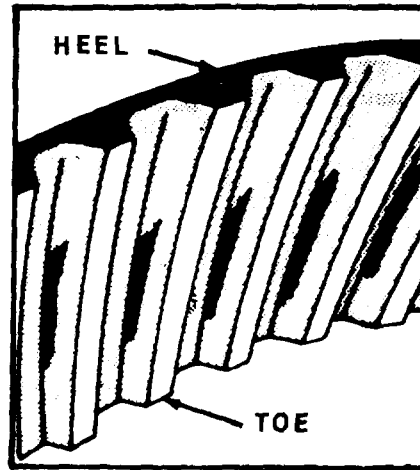

FIGURE-B HIGH NARROW CONTACT

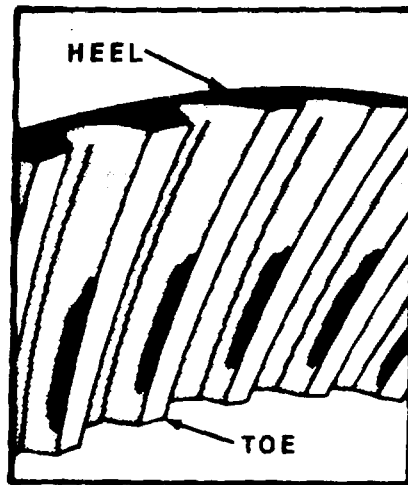
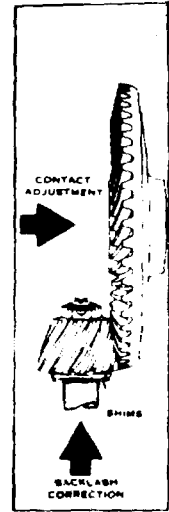

FIGURE-D  
LOW NARROW CONTACT

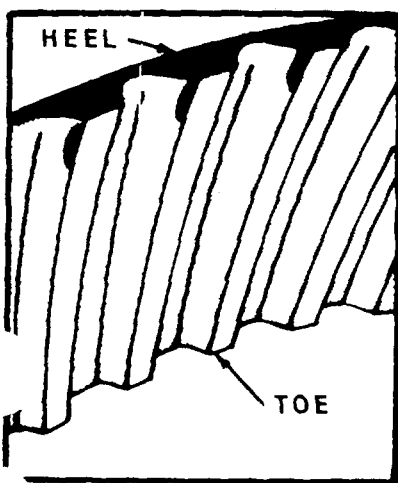
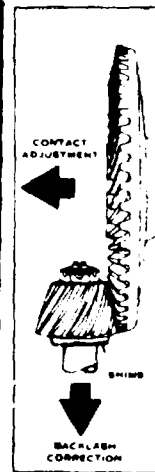

FIGURE-C SHORT HEEL CONTACT

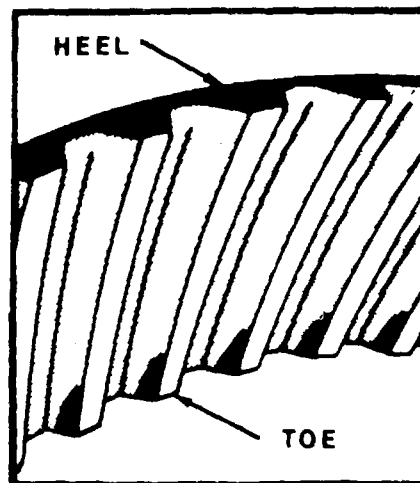
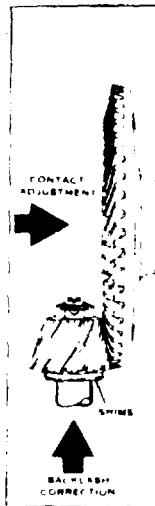

FIGURE-E SHORT TOE CONTACT

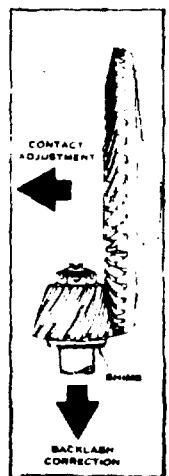

Figure 10 - Tooth Contact



DRIVE UNIT ASSEMBLY

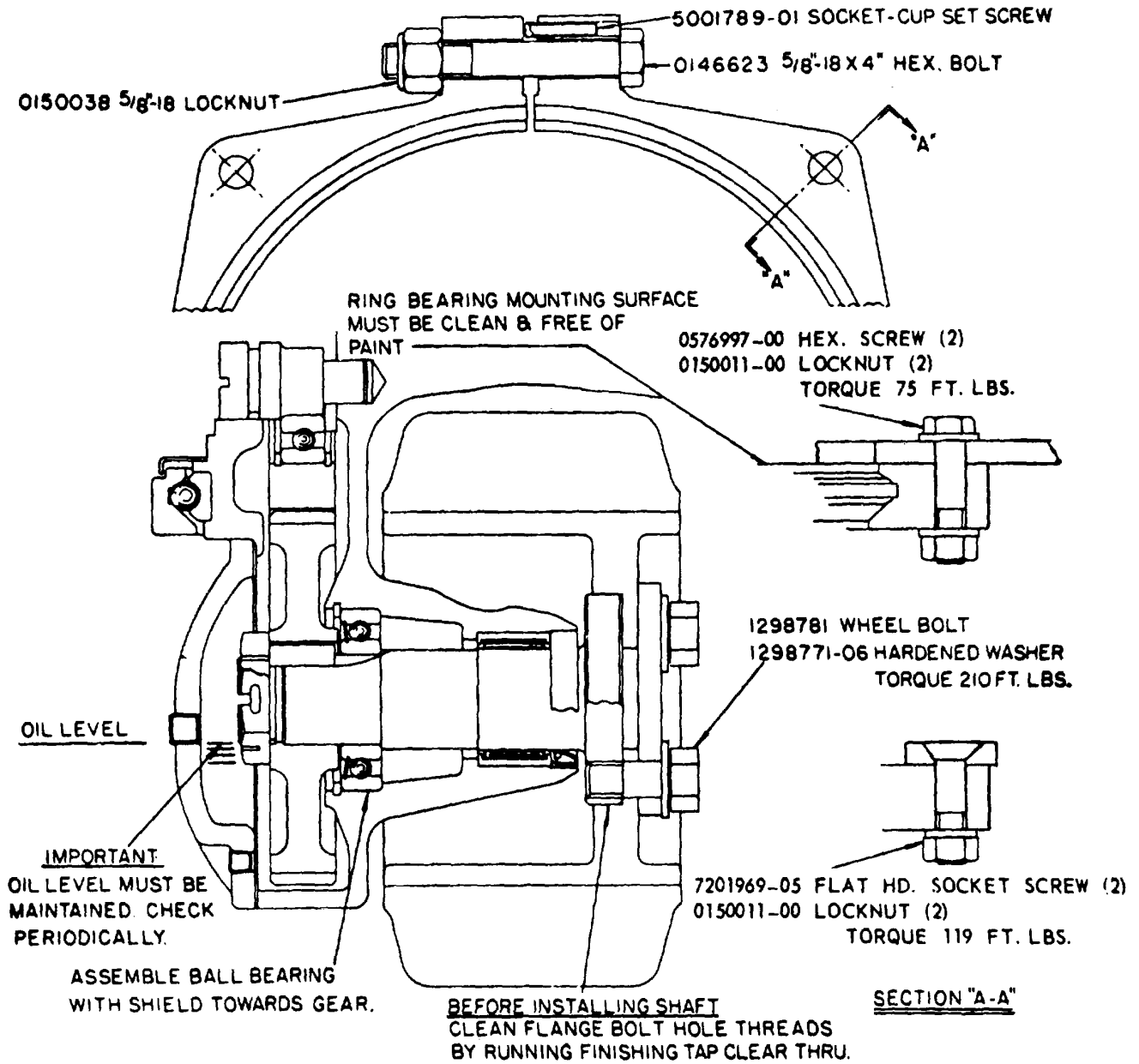

Figure 11 - Drive Unit Ring Gear Adjustment

**DRIVE UNIT ASSEMBLY**

2. Turn steering handle fully in both directions.
  - a. If steering is found to be stiff or tight, loosen four ring bearing mounting bolts loosen ring bearing clamp screw and nut Turn set screw clockwise until steering is made easier without obtaining any free play in ring bearing. Tighten four ring bearing mounting screws before tightening clamp screw, so as not to distort outer race Do not tighten clamp screw excessively.
  - b. If steering is found to be loose or have excessive play, loosen four ring bearing mounting bolts. Loosen ring bearing clamp screw and nut Turn set screw i-counter clockwise until play is removed. Tighten four ring bearing mounting screws before tightening clamp screw locknut, so as not to distort outer race Do not tighten clamp screw excessively

**CHECK POINTS BEFORE AND AFTER ASSEMBLY**

1. Inner and Outer Race
  - a. Before assembly of the inner and outer race way it should be thoroughly checked for Brinneling or any possible condition which could resist the, free rolling of the balls
  - b. The split or slot should not be excessively mushroomed or rolled over which would prevent balls from free rolling
  - c. When assembling onto drive ,unit the inner race split to slot should be mounted 180 apart from the outer ring split.
2. Balls
  - a. There are 72 balls in each unit
  - b. The 1/2 inch balls should be thoroughly checked for cracks, flat spots or missing pieces
  - c. The complete race should be heavily lubricated and maintained in this condition to prevent foreign matter or contamination from getting into bearing race way
  - d. If for any reason the ring bearing is distorted when torque to frame mounting pads (causing a bind) the low pad or pads should be shimmed until no bin(d can be felt when turning handle
  - e. When adjusting the ring bearing it is suggested all instructions be thoroughly read and followed as shown in Figure 11.
  - f. Take particular caution and refer to Fig 11, if drive wheel shaft or bearings are to be replaced

**THE BEST PERFORMANCE FROM ELECTRIC MOTORS CAN BE OBTAINED BY THE FOLLOWING PRECAUTIONS**

- a. Periodically blow out all motors with compressed air
  - b. Inspect brushes and commentator
  - c. The commentator should be perfectly smooth and a rich chocolate brown.
  - d. The brushes must be replaced when they are worn down to such an extent that brush spring is ready to bottom on brush holder.
  - e. When ordering motor parts, be sure to state mode number of truck, serial number of truck model number of motor and voltage.
  - f. In case the brushes are to be replaced, be sure all brushes are changed and properly seated g g  
Brushes must not be too tight in brush holders
- DISASSEMBLY AND ASSEMBLY OF DRIVE MOTOR**
- a. Remove commentator and drive end covers.
  - b. Punch mark the end heads and motor frame for identification, before' removing end heads, so that they will be installed in the same position
  - c. Remove cotter key, nut, motor pinion and shims
  - d. Remove screws and lockwashets holding end head to motor frame Remove end head and bearing.
  - e. Remove screws securing retaining plate to end head Remove plate and bearing.
  - f. Remove protection cover at commutator end head
  - g. 'Lift brushes out of brush holders. and tap armature out of end head, remove armature
  - h. Loosen terminal assembly check nuts and remove field coil wires Remove screws holding commutator end head to motor frame.
  - i. Remove brush holders if they are to be replaced
  - k. Blow out motor with compressed air Thoroughly clean and replace all worn or damaged parts
- WARNING--Make certain commutator and drive end covers are Installed before operating truck.**
- i. Reverse above to install making sure commutator turns freely with a few thousandths end play Refer to paragraph on proper method of fitting brushes and adjusting brush holders  
Note: Always check wiring for kinks or defects.

**DRIVE UNIT ASSEMBLY**

**INSTRUCTIONS FOR FITTING MOTOR BRUSHES**

The trouble which is taken to insure the best possible commutator and brush running conditions, mechanically and otherwise, will pay dividends in longer brush and commutator life and improved commutation.

Brushes of different qualities should never be run together on the same commutator. There should be no exceptions, otherwise commutator may become pitted or badly grooved.

**PREPARATION OF COMMUTATOR**

In order to insure the best possible operation from newly fitted brushes, the commutator should be in good condition. Check the commutator for:

1. Dirt or other foreign matter.
2. Eccentricity.
3. High and low bars, roughness or burning
4. High mica.
5. Grooving of commutator.

If any of the above conditions exist, they should be remedied as follows:

- 1A. Clean the commutator by holding a piece of dry canvas or other hard non-linting material, which is wound around and securely fastened to a piece of wood, against the commutator.
- 2A-3A. If the eccentricity is within .010" and/or roughness is not too great, it may be possible to polish the commutator with one of the several varieties of dressing stones available on the market. Before stoning, clean grease and oil from the commutator, using a cloth saturated with a suitable solution. After stoning, the commutator should be smoothed with a very fine grade of sandpaper, and then polished by using the back of the paper.  
  
When the commutator is too rough or eccentric to be stoned down, it is advisable to turn the commutator in a lathe.
- 4A. Undercut the mica using one of the several types of undercutting tools available on the market. It is well to slightly bevel the segment corners.
- 5A. A commutator that is badly grooved should be ground or turned the same as for roughness or eccentricity. The allowable depth of the groove in the commutator is .010".

After the commutator has been conditioned make sure that it is completely cleaned out by suction (preferred) or by blowing.

A commutator, after having been run in, should be perfectly smooth and a rich chocolate brown in color.

**FITTING OF THE BRUSHES**

Before installing brushes, inspect the brush holders inside and out for burned spots. Make sure that the brush shunts are properly secured to the brushes and that the brushes move freely in the brush holders, within 1/32" total side play.

Fit the new brushes to the commutator brush surface by using a strip of fine sandpaper placed between the face of the brush and the commutator, with the sand side against the brush face. Several one-direction strokes of the sandpaper, pulled in the direction of the commutator rotates with the forward direction of the truck (if a traction drive motor), and in the direction in which the commutator rotates while hoisting (if it is a hoist motor), should be all that is necessary. Only the pressure from the spring should be on the brush while it is fitted in this manner.

Brush fit can be improved by applying a brush-seating stone after using the sandpaper.

Following the installation of new brushes, the motor should be blown out with clean, dry compressed air.

**BRUSH SPRING PRESSURE**

The allowable brush spring pressure is 38 ozs. and should remain constant on all brushes. A too low or too high brush pressure will cause rapid brush wear.

**BRUSH HOLDERS**

It is very important that the brush holders are set parallel to the axis of the commutator, and that the distance between the bottom of the holders and the commutator surface does not exceed 1/8".

As mentioned above, the brush holders should be inspected for burned spots, both inside and out, that may have been caused by flashing at the commutator. Any roughness on the inside may be removed with fine sandpaper glued to a flat piece of wood.

**CONTROL HANDLE ASSEMBLY**

**HANDLE CONTROL SWITCH**

The switch, located in the handle assembly, has three speeds forward and three speeds reverse. Operator controls rate of speed change through the control plate located on top of the control handle. When handle plate is removed, the following should be checked:

1. Observe condition of each contact tip and switch blade
2. Check all wires, connectors, screws, nuts and terminals for tightness. Note: Check truck for ground whenever possible. If truck has a ground, repair and recheck.

**REMOVE HANDLE ASSEMBLY**

1. Disconnect battery.
2. Unscrew both knobs and remove drive unit cover.
3. Disconnect and tag wires at terminal block on top of drive unit. Disconnect cutout switch at brake release arm.
4. Refer to "Removal of Torsion Springs" to remove handle assembly.
5. To install handle refer to "Reassembly of Torsion Springs" and reverse above Instructions.

**REMOVE TRAVEL CONTROL PLATE**

Refer to Figure 12

**NOTE:** It is not necessary to remove handle assembly to disassemble control plate, switch assembly or push buttons.

1. Disconnect battery.
2. Remove four round head screws (2) and lockwashers (3).
3. Remove guard (1).
4. Remove cotter pin (9).
5. Remove two roll pins (7).
6. Remove travel control plate (6).
7. Remove brake cam (31) from handle.

**REMOVAL OF TORSION SPRINGS**

Refer to Figure 12

1. Remove the cap nuts (22) and drive unit housing (not shown) and replace cap nuts with standard 1/2" 20 hex nuts. Tighten hex nuts **securely**.
2. Loosen and remove one hex bolt (25) at a time. If a support (24 or 30) starts to rotate from the torsion spring tension when loosening a bolt, retighten the 1/2" 20 nuts before removing the hex bolts.
3. **Very carefully** loosen the 1/2" 20 hex nuts that you installed next to the supports. Hold the handle firmly with one hand while loosening a hex nut with the other. As each nut is loosened, the tension of each spring will cause that support to rotate until the spring relieves itself.
4. Remove the bolts from the supports.
5. Remove the supports and slip the springs out of the handle.
6. Remove pivot shaft (28) from handle.
7. Remove brake cam from handle. Refer to "Brake Shoes and Linkage".

**REASSEMBLY TORSION SPRINGS**

1. Install brake cam (31) into handle.
2. Insert pivot shaft (28) into handle
3. Install springs into supports and insert supports onto pivot shaft. Spring (27) is a flat section and spring (29) is a round section.
4. Install a hex screw (25) and lockwasher (26) in the support (30), but leave it loose enough that the support can pivot on the hex bolt.
5. Hold handle in up position and insert a pinch bar in the bolt hole of the other support (24). Rotate this support (24) to the bolt-down position. This will preload the springs. Make sure the bolt hole in support and housing line up for bolt installation.
6. While holding support in position with pinch bar tighten standard 1/2" 20 Hex nuts **securely** so that supports and springs will not move.
7. Remove pinch bar, and install the other hex screw (25) and lockwasher (26) and torque both bolts to 110-120 ft. lbs.

CONTROL HANDLE ASSEMBLY

CONTROL HANDLE ASSEMBLY

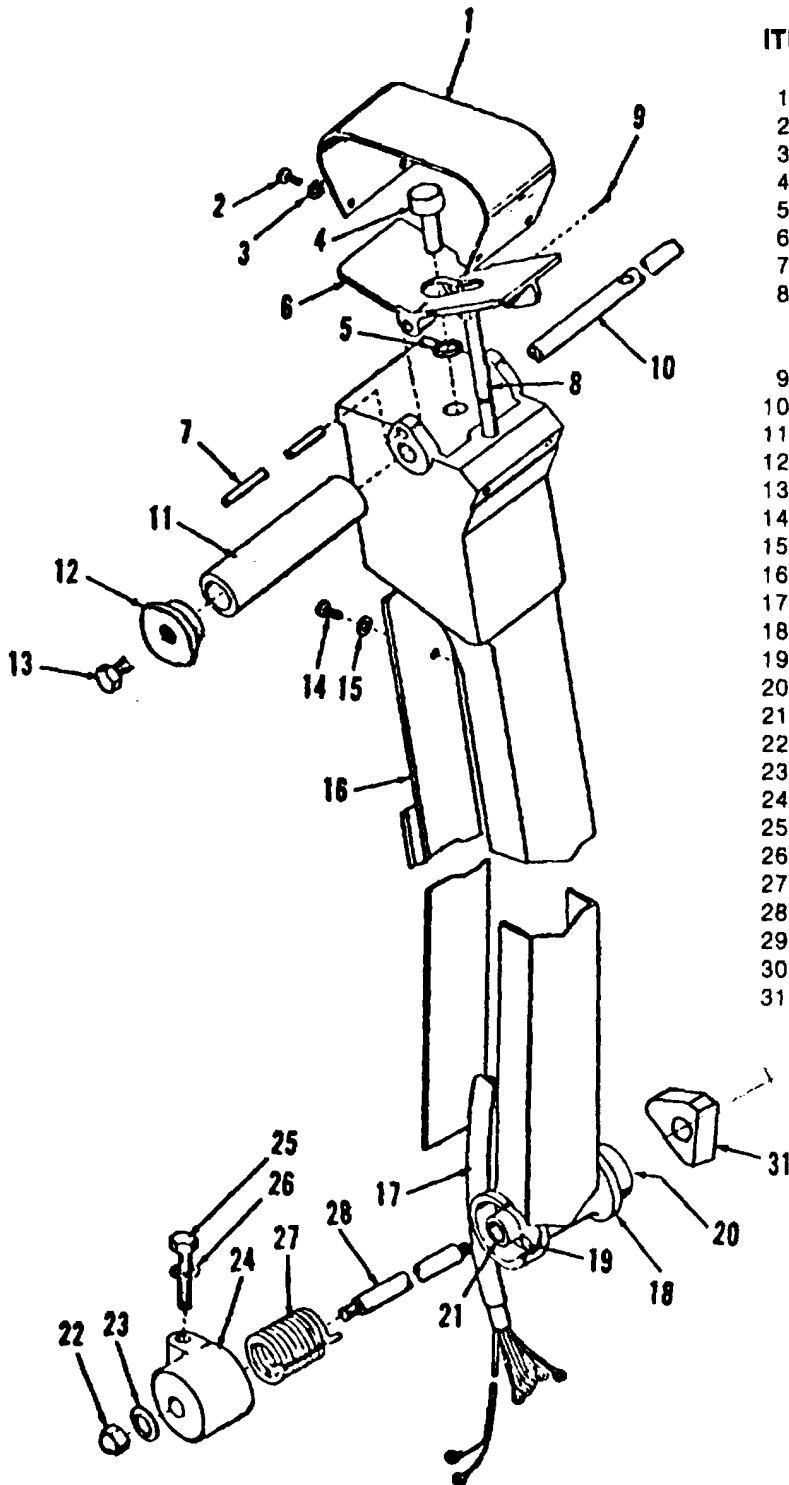

ITEM	DESCRIPTION
1	Guard
2	Round Head Screw
3	Lockwasher
4	Horn Button
5	Retaining Ring
6	Travel Control Plate
7	Roll Pin
8	Control Rod Rod End
	Drive-Loc Pin
9	Cotter Pin
10	Handle Bar
11	Grip
12	Knob
13	Self-Locking Screw
14	Round Head Screw
15	Flat Washer
16	Cover W/Rubber Bumper
17	Wire Harness
18	Handle
19	Insert
20	Insert
21	Bushing
22	Cap Nut
23	Shakeproof Lockwasher
24	Support
25	Hex Hd. Screw — Torque 110-120 ft. lbs.
26	Lockwasher
27	Torsion Spring
28	Pivot Shaft
29	Torsion Spring
30	Support
31	Brake Cam

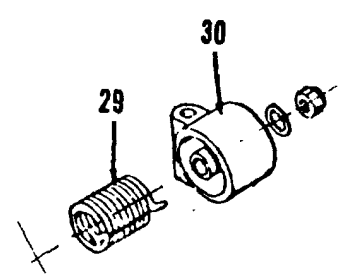
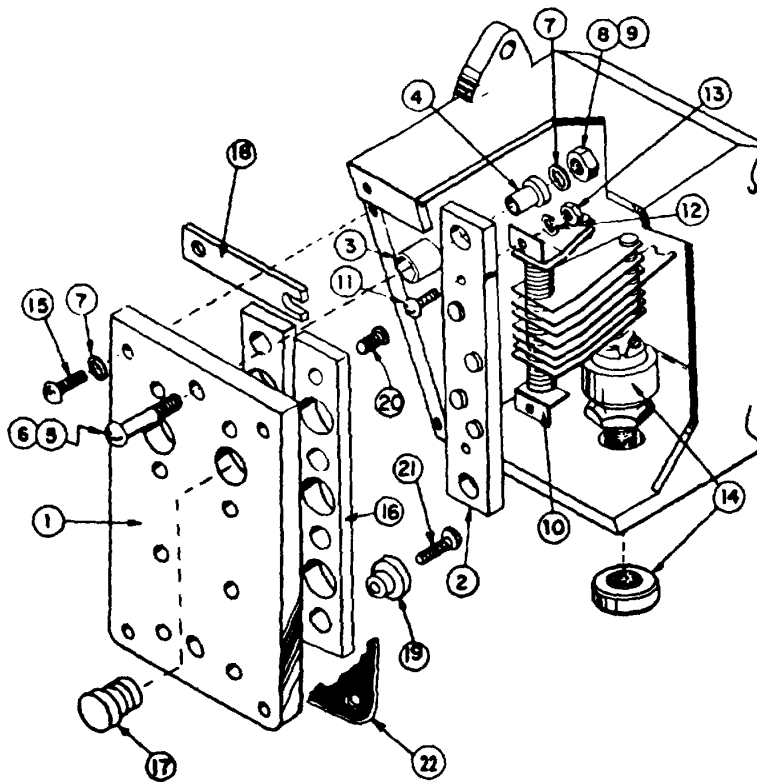

Figure 12 - Control Handle

CONTROL HANDLE ASSEMBLY



ITEM	DESCRIPTION
1	Plate
2	Bar
3	Spacer
4	Bushing
5	Round Head Screw
6	Round Head Screw
7	Shakeproof Lockwasher
8	Hex Nut
9	Hex Jam Nut
10	Switch Assembly
11	Round Head Screw
12	Shakeproof Lockwasher
13	Hex Nut
14	Lock Switch W/Keys
15	Hex Screw
16	Insulator Strip
17	Button
18	Switch Blade
19	Insulator
20	Round Head Screw
21	Round Head Screw
22	Gasket

Figure 13 - Control Handle Switch Assembly

- Remove 1/2" hex nuts, and install drive unit housing with the cap nuts (22) and lockwashers (23).

**REMOVE SWITCH ASSEMBLY**

(Refer to Figure 13)

- Disconnect battery.
- Remove four round head screws (15) and lockwashers (7).
- Pull plate (1) out enough to unsolder wire leads at switch (10).
- Remove remaining leads from terminals.

- Remove plate (1) with switch (10).
- Remove nuts (8-9), lockwashers (7), round head screws (5-6), bushings (4) and spacers (3).
- Remove switch assembly.
- Reverse above to Install.

**WARNING--**Make certain gasket (22) is installed between cover and housing before operating truck.

PALLET AND LIFT LINKAGE

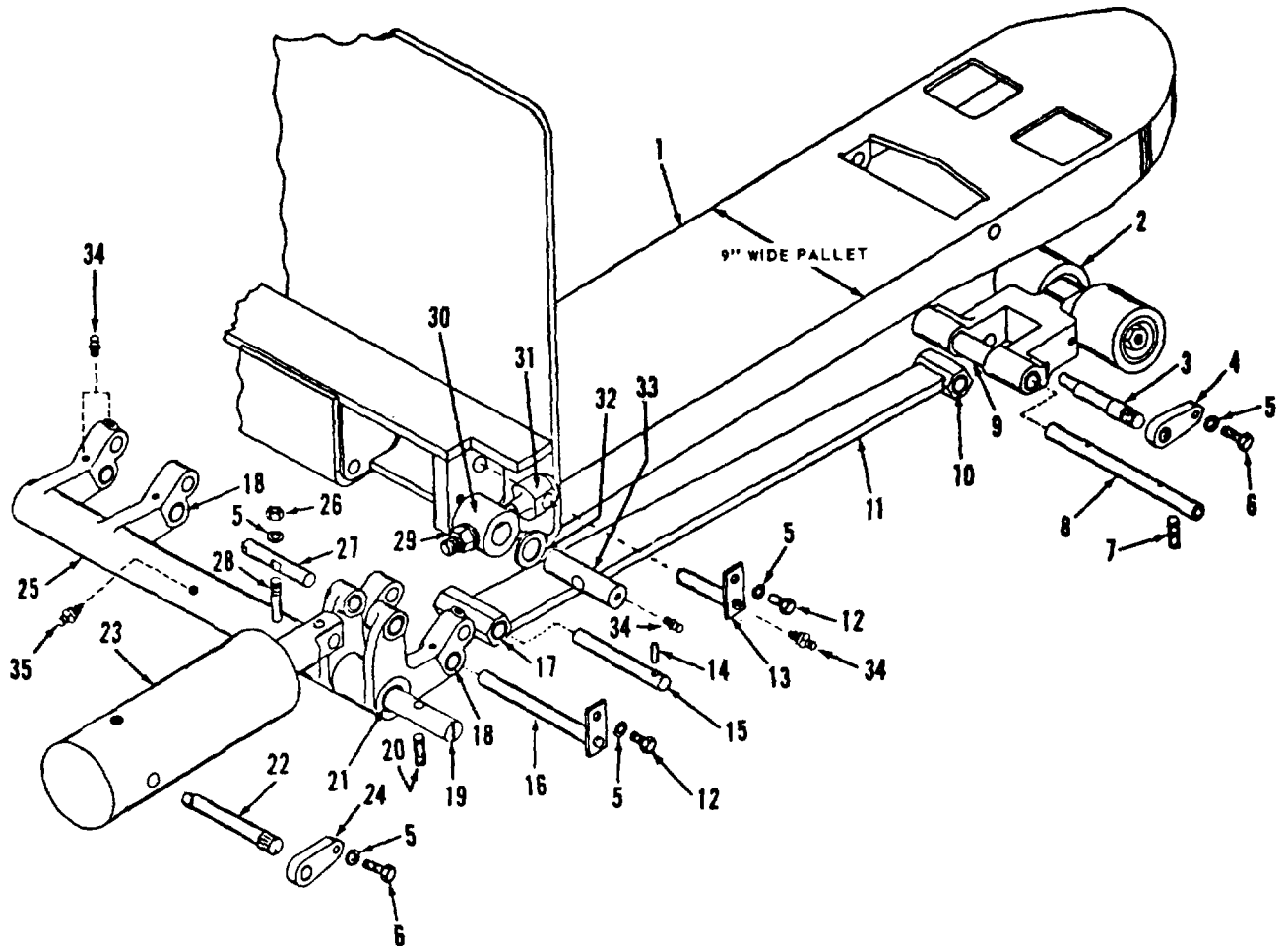

Figure 14 - 9 Inch Wide Pallet and Lift Linkage

ITEM	DESCRIPTION	ITEM	DESCRIPTION
1	Pallet Fork	18	Bushing
2	Load Wheel Group	19	Rocker Shaft
3	Eccentric Shaft	20	Set screw
4	Shaft Lock	21	Bushing
5	Lockwasher	22	Eccentric Shaft
6	Hex Screw	23	Lift Cylinder
7	Set screw	24	Shaft Lock
8	Axle Link Pin	25	Rocker Arm
9	Spacer	26	Hex Nut
10	Bushing	27	Pin
11	Pull Rod	28	Lock Pin
12	Hex Screw	29	Locknut
13	Pin Assembly	30	Collar
14	Set screw	31	Adjusting Stud - W/Nut
15	Pin	32	Thrust Washer
16	Shaft Assembly	33	Pin
17	Bushing	34	Lube Fitting
35	Lube Fitting		

**PALLET AND LIFT LINKAGE**

**LIFT LINKAGE**

When the hoist button on the control handle is pushed, the electrical powered hydraulic pump operates the cylinder in a retracting motion which pulls the rocker arm back. The arcing movement of the rocker arm provides lifting action to both ends of the pallet fork. Both the attachment to the pallet of the levers at both ends of the rocker arm and by the pulling action of the pull rods which in turn pull the load wheel assemblies in an arcing manner provides the motion to raise the pallet fork. The adjusting studs act both as pallet levelers and stabilizers.

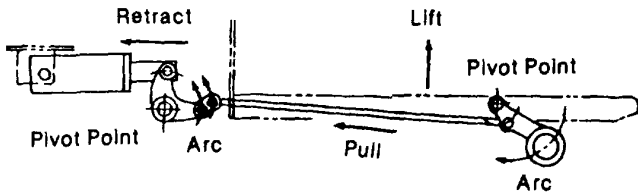

Figure 14-A Lift Linkage

**REMOVE PALLET ASSEMBLY**

Refer to Figure 14

- a. Using power, raise pallet assembly to full extent.
- b. Disconnect and remove battery.
- c. Remove nut (26) and lockwasher (5) from lock pin (28) and remove lock pin.
- d. Place blocks under the truck frame at pallet end of battery compartment.
- e. Place blocks under pallet forks at battery compartment end.
- f. Remove pin (27) to free cylinder.
- g. Remove set screws (20)
- h. Tap rocker shaft (19) out of frame from access holes.
- i. Remove hex screws (12) and lockwashers (5) and remove pin assemblies (13) to release adjusting stud.

**NOTE :** Do not disturb locknut (29) setting unless replacement of stud is necessary.

- j. Pull pallet assembly away from frame.

**PALLET DISASSEMBLY**

Refer to Figure 14

- a. Position pallet assembly on its side and block.
- b. Mark pull rods (11) and pallet forks (1) R.H. (shown) and L.H. to facilitate reassembly.
- c. Remove hex screw (6) and lockwasher (5).
- d. Tap out eccentric shaft (3) with shaft lock (4) attached to release pull rod.
- e. Remove hex screw (12) and lockwasher (5) and remove shaft assembly (16).
- f. Slide rocker arm (25) with pull rods attached out of pallet fork (1).
- g. Remove set screw (14) and remove pin (15) to release pull rod.
- h. Remove set screw (7) and axle link pin (8) to remove load wheel group.

**DISASSEMBLE LOAD WHEEL ASSEMBLY**

**NOTE :** It is not necessary to remove load wheel assembly to replace wheels. Use the following when wheel assembly is in or out of truck.

Refer to Figure 15.

- a. When wheel assembly is in truck raise pallet to full extent, then block pallet to raise wheels off the floor.
- b. Disconnect battery.
- c. Remove socket head screw (7) and locknut (6).
- d. Remove wheel from axle (1), also spacer and spacer washer (3).

**LOAD WHEEL INSPECTION**

**NOTE :** During a complete overhaul it is advised that all bushings, bearings, spacers and washers be replaced.

- a. Thoroughly clean all parts in a suitable solvent. Do not use gasoline to clean bearings. Do not soak polyurethane wheels in the solvent.
- b. Replace worn or damaged bearings, spacers and spacer washers.



**PALLET AND LIFT LINKAGE**

- c. Replace worn or damaged bushings in rocker arm. Bushing nominal I.D. is .750".

- g. Install and tighten socket screw (7).

- h. Rotate wheel and lubricate at fitting.

**LOAD WHEEL REASSEMBLY**

Refer to Figure 15

- a. Install spacer and washer (3) in the same order of disassembly.
- b. Place a small amount of grease on bearing balls for lubrication.
- c. Insert one bearing (4) in wheel (5) with seal facing outward.
- d. Pack wheel with grease and install other bearing with seal facing outward.
- e. Install wheel onto axle.
- f. Install and tighten locknut (6). Rotate wheel to be sure it does not bind.

**PALLET REASSEMBLY Refer to Figure 14**

**NOTE:** During a complete overhaul it is advised that all bushings in the linkage be replaced.

- a. Place a pull rod into a load wheel assembly and insert an eccentric shaft (3) with a shaft lock (4) attached. Bushing at this end of pull rod is a nominal .875" I.D.

**NOTE:** When shaft lock has been removed from eccentric shaft, first insert eccentric shaft and place shaft lock on shaft and turn until load wheel assembly bottoms against pallet surface. Install shaft lock in proper position.

- b. Install hex screw (6) and lockwasher (5) and tighten.

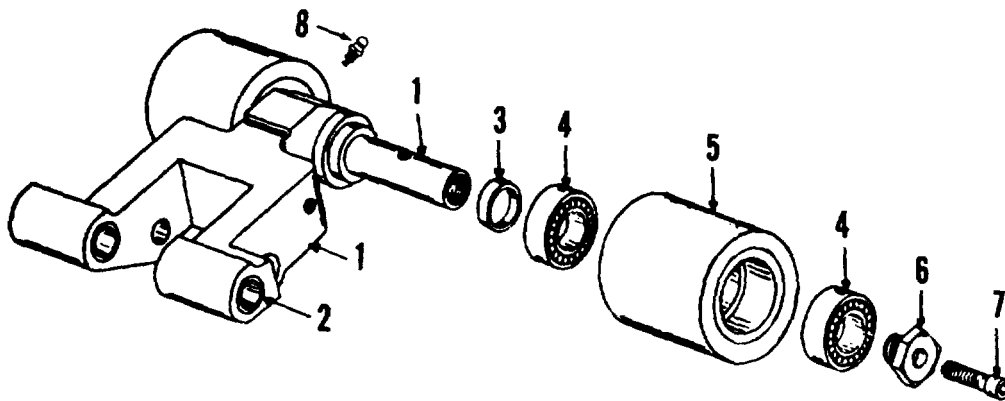

ITEM	DESCRIPTION
1	Link and Axle
2	Bushing
3	Spacer
4	Spacer Washer
4	Ball Bearing
5	Poly Load Wheel
6	Locknut
7	Socket Head Screw
8	Lube Fitting

Figure 15 - Load Wheel Assembly

**PALLET AND LIFT LINKAGE**

- c. Insert other end of pull rod, L.H. and R.H. as marked, into pallet with enough room to install pin (15) and set screw (14) into rocker arm. Bushing at this end of pull rod is a nominal .750" I.D.
- d. Engage rocker arm, with pull rod and load wheel assemblies attached, into pallet and install shaft assemblies (16).
- e. Install and tighten hex screws (12) and lockwashers (5).
- f. Position load wheel assembly into pallet fork.
- g. With spacer (9) in place, insert axle link pin (8) and install and torque set screw (7) to 75-85 ft. lbs.
- h. Lubricate at all fitting points.

**INSTALL PALLET ASSEMBLY**

Refer to Figure 14

- a. Position pallet assembly by blocking at truck frame and align rocker arm (25) shaft hole with holes in frame. Bushings are a nominal 1.125" I.D.
- b. Lubricate rocker shaft (19) insert and tap into place.
- c. Align set screw holes, install and torque set screws (20) to 75-85 ft. lbs.
- d. Install pin assemblies (13), hex screw (12) and lockwasher (5).
- e. Align cylinder (23) piston rod hole with holes in rocker arm (25) levers and insert pin (27). Install nut (26) and lockwasher (5). Bushings are a nominal .875" I.D.
- f. Lubricate at fitting points.
- g. Remove blocks. Lower truck to floor.
- h. Adjust pallet assembly as follows.

**ADJUST PALLET ASSEMBLY**

- a. Connect battery raise and lower pallet assembly a few times. Remove cylinder breather plug. Fill with new clean hydraulic oil to proper level, within 1/8" of filler plug opening. Install breather plug. Operate hydraulic unit a few times. Remove battery. Place near truck and insert battery plug.

**NOTE:** Use a flat level section of concrete or similar flat surface to check pallet measurements.

- b. Lower pallet forks all the way. Place a straight edge across the forks at load wheels. Check distance from floor to the top surface of both forks. This dimension should be 3-3/8". Move straight edge to battery box end of forks and measure both sides. These four points should be within 1/8". If not, the following adjustments should be made.

The adjustments for proper fork height are done by rotating the eccentric pins at the load wheels and readjusting the adjusting studs at the frame end. The adjustment of the load wheels to full resting position or "bottom out" can be set by aligning the O.D. of the load wheels with the top surface of the pallet fork, thru the access holes, can be made in the following way.

Refer to Figure 14.

- a. Lift one side of truck high enough to work under fork.
- b. Remove hex screw (6) and lockwasher (5) from shaft lock.
- c. Rotate shaft lock (4) in either direction until load wheel assembly reaches correct position.
- d. Relocate shaft lock and install lockwasher and screw.
- e. Repeat on other pallet fork.
- f. Right truck and check fork heights.

These adjustments will change the pallet fork heights at the back plate. The following adjustments can be made to the adjusting studs.

1. To lower the fork heights, increase the amount of the stud adjustment as follows.
  - a. Back off locknut on the pin (13) side of the collar (30).
  - b. Tighten locknut on the stud side of the collar.
2. To raise the forks heights decrease the amount of the stud adjustment as follows.
  - a. Back off locknut on the stud side of the collar (30).
  - b. Tighten locknut on the pin (13) side of the collar.

**HYDRAULIC SYSTEM**

These adjustments will also change the load wheel settings. Therefore the load wheels may have to be readjusted.

Adjustment of the lift cylinder (23) eccentric pin (22) is necessary only if the effective stroke of the lift cylinder is insufficient to attain the "bottom out" position of the load wheels.

**HYDRAULIC SYSTEM**

The hydraulic system consists of a hydraulic pump with built-in relief valve set at 2600 PSI and a solenoid operated pressure release valve, a single acting hydraulic cylinder spring loaded to assist gravity lowering of empty pallet forks.

**NOTE:** It will be necessary to turn truck on its side whenever repairs are required on pump and motor or solenoid release valve.

**TURN TRUCK ON ITS SIDE**

- a. Lower pallet assembly all the way.
- b. Disconnect and remove battery.
- c. Using control handle as a fulcrum, turn truck on its right side.
- d. Reverse above to right truck for use.

**REMOVE AND REPLACE PUMP AND MOTOR ASSEMBLY**

Refer to Figure 17  
Refer to Figure 17

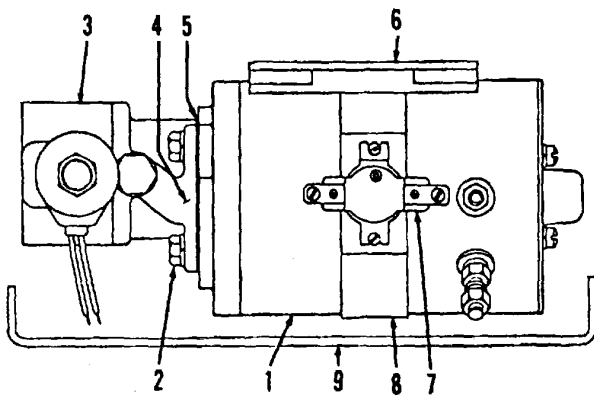

Figure 16 - Hydraulic Pump, motor and Solenoid Release Value

- a. Turn truck on its right side. Refer to above.
- b. Remove and tag wires (2).
- c. Remove high and low pressure hoses at pump fittings and drain.
- d. Remove high pressure hose from pressure switch at pump fitting and drain.
- e. Remove four screws.
- f. Remove four hex screws and lockwasher (3).
- g. Remove pump and motor assembly (4).
- h. Reverse above to install.
- i. Right truck to its wheels for use.
- j. Check operation of hoisting with and without a load while maintaining proper oil level in cylinder, about 1/8" below filler hole.

**REMOVE AND REPLACE HYDRAULIC PUMP**

Refer to Figure 16

- a. Remove pump and motor, as above.
- b. Remove four hex screws and lockwashers (2) and remove pump (3), and coupling (4) from motor.
- c. Reverse to reassemble pump and motor, taking care to seat coupling correctly.

ITEM	DESCRIPTION
1	Motor
2	Hex Screw Lockwasher
3	Pump
4	Coupling
5	Gasket
6	Foot
7	Round Head Screw Thermostat
8	Bracket
9	Splash Pan

HYDRAULIC SYSTEM

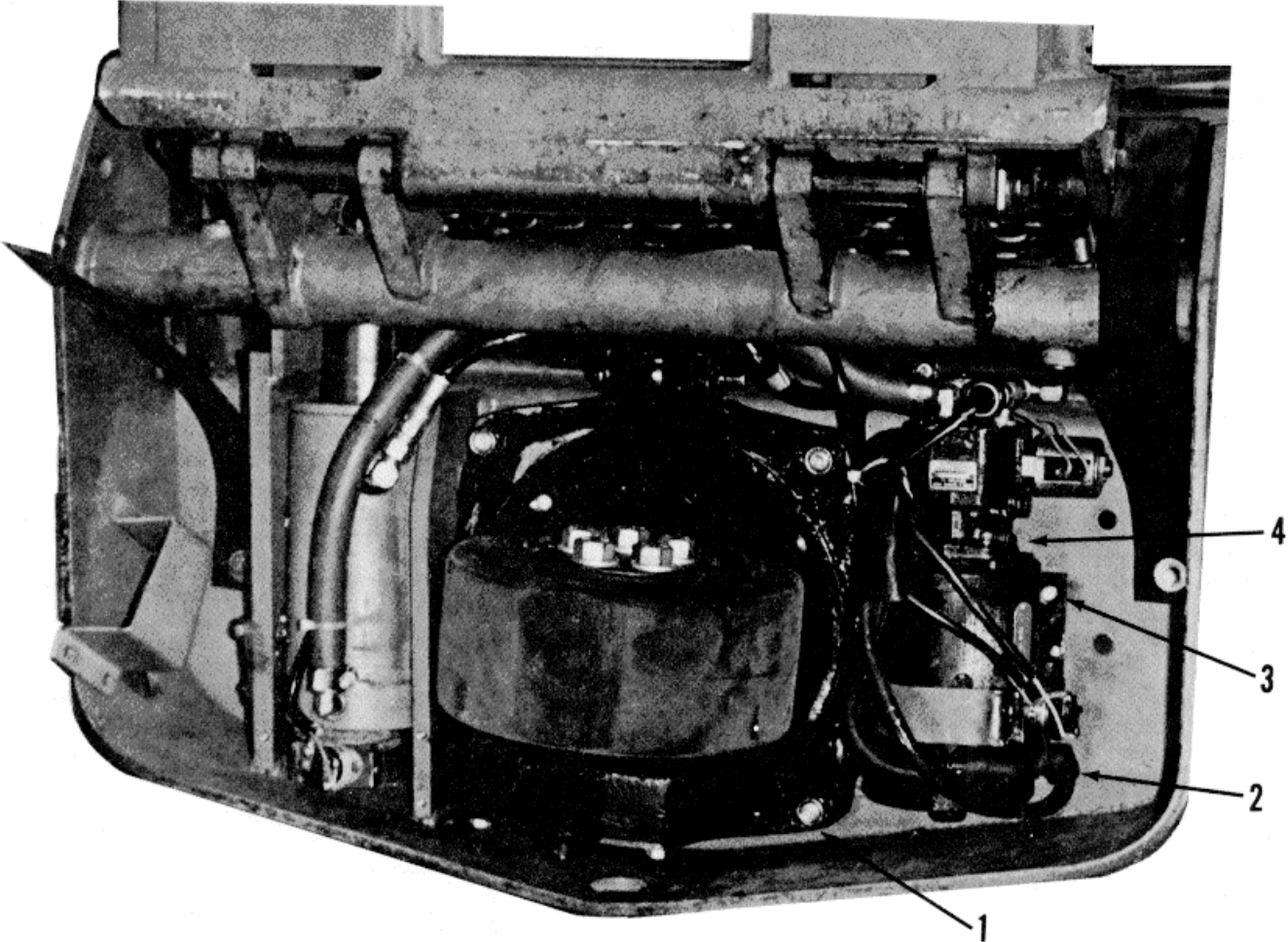

ITEM	DESCRIPTION
1	Locknuts and Screws
2	Wires
3	Hex Screws
4	Pump and Motor

Figure 17 - Hydraulic System (with splash pan removed)



**HYDRAULIC SYSTEM**

**PUMP MOTOR DISASSEMBLY AND REASSEMBLY**

Refer to Figure 18

- a. Remove pump from motor as above.
- b. Mark end heads and frame to facilitate reassembly of heads in correct positions.
- c. Remove two thru bolts (7) and remove commutator end head (10).
- d. Remove brushes (2) with brush springs (9). Inspect brushes for excess wear. Refer to "instructions For Fitting Brushes" on page 68. The allowable brush spring pressure is 30 ozs.
- e. Tap off drive (pump) end head (4) and remove armature (6) and D.E. bearing (5). Refer to "Preparation Of Commutator" on page 68.
- f. Blow out motor with compressed air, and replace worn or damaged parts.
- g. Reverse above to reassemble, making sure commutator turns freely with a few thousandths end play.

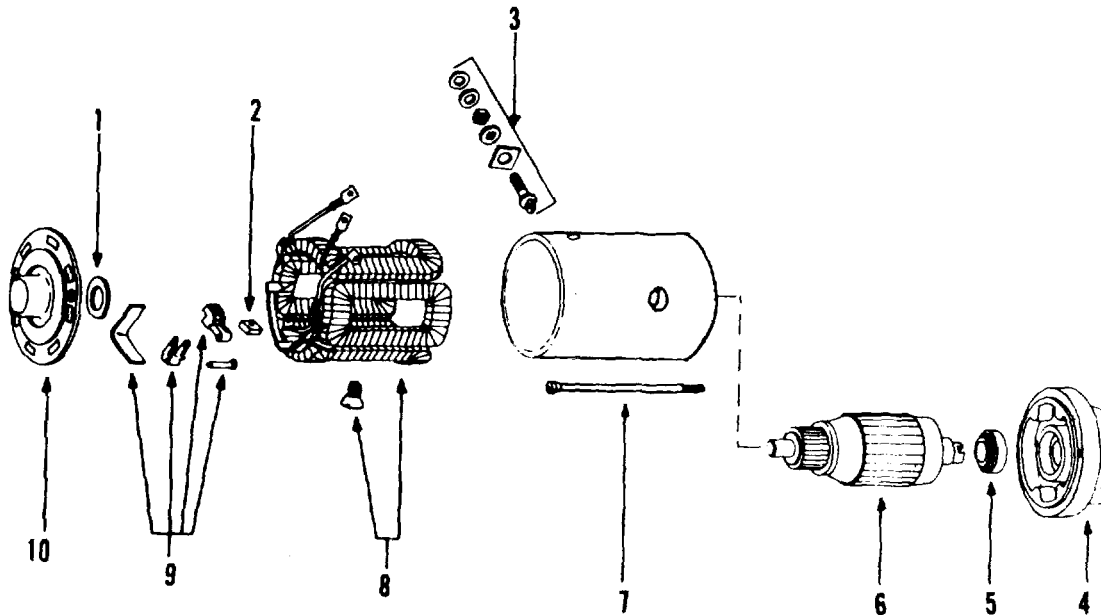

ITEM	DESCRIPTION
1	Thrust Washer Package
2	Brush Set
3	Terminal Stud Package
4	Drive End Head
5	D.E. Bearing
6	Armature
7	Thru Bolt Package
8	Field Coil Package
9	Brush Holder and Spring Package
10	Commutator End Head

Figure 18 - Motor - Hydraulic Lift Pump

HYDRAULIC SYSTEM

PUMP DISASSEMBLY AND REASSEMBLY

Refer to Figure 18

**NOTE:** If the oil seal (2) must be replaced, it may be pried out and replaced without disassembling pump. The needle bearings do not usually have to be replaced, if so, a new pump is recommended.

- a. Remove eight 12-point headed screws (19) and tap housing (5) and stator (9) gently with a plastic hammer to separate. Do not disturb dowel pins (20).
- b. Remove drive shaft (1) with gear (4) and Idler shaft (10) with gear (4).
- c. Remove snap rings and gears from shafts. Remove key (1) and drive pin (6) from shafts.
- d. Clean and Inspect all pump parts.
- e. Gears with scored surfaces or galled teeth must be replaced.
- f. Pump must be replaced if there is scoring in gear pockets or damage to sealing surfaces.
- g. Install new oil seal in the stator. Assemble gears on shafts in reversed order of disassembly.
- h. Insert shaft assemblies into stator. Oil well and assemble housing to stator.
- i. Turn drive shaft while tightening screws to make sure there is no binding.

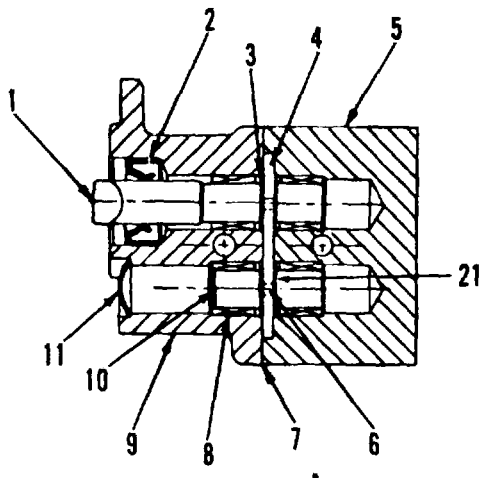
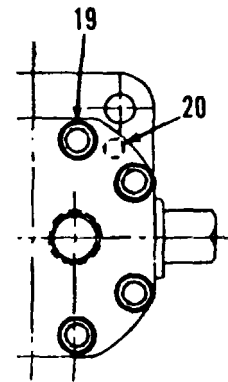
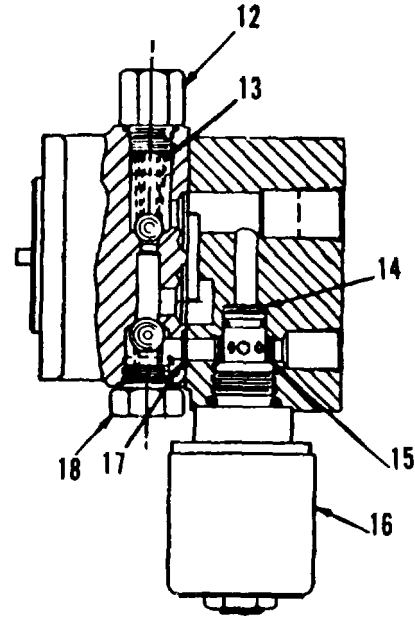

Figure 19 - Hydraulic Pump W/Solenoid Release Valve

ITEM	DESCRIPTION
1	Drive Shaft Key
2	Oil Seal
3	Snap Ring - Drive Shaft
4	Gear - 1/4" Wide
5	Stator
6	Drive Pin
7	Gasket
8	Needle Bearing

**HYDRAULIC SYSTEM**

- 9 Housing
- 10 Idler Shaft
- 11 Welch Plug
- 12 Hex Cap Nut  
Gasket
- 13 Adjusting Screw  
Spring and Ball Assembly  
Spring
- 14 Orifice Plate (.078" Restriction)
- 15\* Filter
- 16 Solenoid Release Valve
- 17 "O" Ring
- 18 Cap  
Gasket  
Spring and Ball Assembly
- 19 12 Point Hd Screw  
Moly Lockwasher
- 20 Dowel Pin
- 21 Snap Ring - Idler Shaft

- 3d. Excessive Internal wear.
- 4a. Low oil level.
- 4b. Air leaking into suction line.
- 4c. Wrong kind of oil.

**REMEDIES**

- 1a. Fill reservoir.
- 1b. Change to proper viscosity.
- 1c. Clean line and check for size.
- 2a. Fill reservoir.
- 2b. Drain reservoir and refill with clean oil.
- 2c. Set to correct pressure. - (2600 PSI)  
Remove hex cap nut (12) and gasket. Turn adjusting screw (13) clockwise for higher pressure or counter clockwise for lower pressure.

**NOTE:** Filter must be replaced any time solenoid release valve is removed.

**HYDRAULIC PUMP TROUBLE SHOOTING  
POSSIBLE PUMP TROUBLE**

- 1. Noisy pump caused by cavitation.
- 2. Oil heating.
- 3. Shaft seal leaking.
- 4. Foaming oil.

**CAUSES**

- 1a. Oil supply low.
- 1b. Oil too heavy
- 1c. Suction line plugged or too small
- 2a. Oil supply low
- 2b. Contaminated oil.
- 2c. Relief valve setting too high or too low.  
Set to correct pressure (2600 P.S.I.)
- 2d. Oil too light.
- 3a. Worn shaft seal.
- 3b. Leaking housing.
- 3c. Bearings out of position

- 2d. Drain reservoir and refill with proper viscosity oil.
- 3a. Replace shaft seal.
- 3b,c,d. If replacing the shaft seal does not stop leakage, the pump should be disassembled and checked for Items c and d.
- 4a. Fill reservoir.
- 4b. Tighten fittings.
- 4c. Drain and fill reservoir with non-foaming hydraulic oil.



**HYDRAULIC SYSTEM**

Figure 20 - Solenoid Release Valve

ITEM	DESCRIPTION
1	Coil - 12 Volt
2	Seal and Back-Up Washer Kit

**LIFT CYLINDER  
REMOVE FROM TRUCK**

Refer to Figure 14.

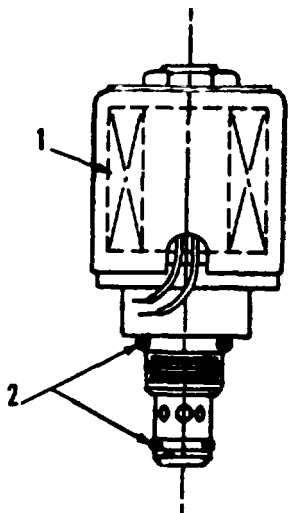
- a. Turn truck on left side as follows:
  1. Lower pallet forks all the way.
  2. Disconnect and remove battery.
  3. Using control handle as a fulcrum, turn truck on its left side.
- b. Disconnect hoses at cylinder (23) and drain.
- c. Remove hex nut (26) and lockwasher (5) and tap out lock pin (28).
- d. Remove cylinder ram pin (27).
- e. Remove hex nut and lockwasher (24) securing cylinder eccentric shaft (22).
- f. Remove hex screw (6) and lockwasher (5) securing splined shaft lock (4).

- g. Tap eccentric shaft with shaft lock (4) attached, from truck frame and cylinder (23).
- h. Remove lift cylinder (23) from truck frame and drain.

**CYLINDER DISASSEMBLY**

Refer to Figure 21.

**CAUTION:** Lift cylinder is spring loaded. Use extreme care when disassembling.

- a. Using a suitable spanner wrench, 5/16" pins on a 3-1/4" dia., loosen, do not remove, the cylinder gland, (head), (13)
- b. Position cylinder assembly in an arbor press with piston rod facing up.
- c. Partially depress piston rod. Be certain cylinder assembly is securely held in place.
- d. Remove cylinder gland (13).
- e. Slowly release pressure on arbor press to release spring compression.
- f. Remove piston and rod assembly. Remove compression springs.
- g. Remove piston retainer, 2-1/2" across flats.
- h. Remove piston with a suitable spanner wrench, 1/4" pins on a 2-3/4" dia.
- i. Remove piston backing plate and piston packing

**INSPECTION OF CYLINDER PARTS**

- a. Check cylinder wall, piston (4), Piston rod (9) and gland (13) for smoothness and concentricity.
- b. Check spring compression force.
  1. Large spring (2) should be 324 lbs. of compression for 4" of stroke.
  2. Small spring (5) should be 124 lbs of compression for 4" of stroke.

**CYLINDER REASSEMBLY**

- a. Apply a small amount of vaseline to "O" ring and back-up ring (7) and insert into piston (4).

**HYDRAULIC SYSTEM**

- b. Insert packing ring (6) into piston.
- c. Install backing plate (8), piston with packing and piston retainer (3) onto piston rod (9).
- d. Apply Vaseline to "O" ring and back-up ring (11), packing (12) and wiper ring (14) and insert into gland (13).
- e. insert piston rod into gland assembly.
- f. Install springs (2) and (5) into piston rod and insert complete piston rod assembly into cylinder.
- g. Position cylinder assembly in an arbor press with piston rod facing up. Be certain cylinder is securely held in place Partially depress piston rod.
- h. Tighten down gland.
- i. Release pressure on arbor press and remove cylinder.

**CYLINDER INSTALLATION**

Refer to Figure 14.

- a. Position cylinder into truck frame, allowing beveled side of piston rod to enter rocker arm levers.
- b. Insert eccentric shaft (22) through frame and cylinder. Place splined shaft lock (4) on shaft and revolve until eccentric seats. Reposition lock to Install hex screw (6) and lockwasher (5).
- c. Install pin (27) through levers and piston rod.
- d. Install lock pin (28), with hex nut (26) and lockwasher (5)
- e. Install hoses at cylinder. Tighten connections. Refer to Figure 22 Hydraulic Diagram.
- f. Right truck to its wheels for use.
- g. Operate to full extent, hoist and lower, while maintaining oil level in cylinder to within 1/8" below filler hole.
- h. Check for leaks at all hydraulic connections.

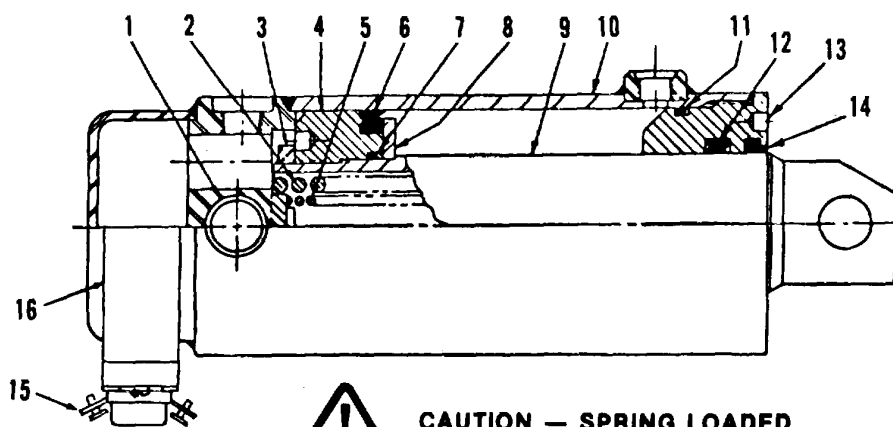

**CAUTION — SPRING LOADED**

ITEM	DESCRIPTION	ITEM	DESCRIPTION
1	Bushings	9	Piston Rod
2	Spring	10	Tube Weldment
3	Piston Retainer	11	"O" Ring
4	Piston	12	Back-Up Ring
5	Spring	13	Packing
6	Packing	14	Gland
7	"O" Ring	15	Wiper Ring
8	Back-Up Ring	16	Thermostat
	Backing Plate		Bracket

Figure 21 - Hydraulic Lift Cylinder

**HYDRAULIC SYSTEM**

**TROUBLESHOOTING HYDRAULIC SYSTEM**

The hydraulic system is a precision mechanism and its continued smooth operation depends on proper care. It should be kept as clean as possible. The oil should be checked not only for proper level, but also for cleanliness at established intervals.

If system does not operate properly, a few preliminary checks should be made before proceeding.

Proper oil level - 1/8" from inside contour of cylinder.

Possible leakage at tubing or hose connections.

Possible loose electrical connection or short.

**NOTE:** If the above checks do not reveal the trouble cause, conduct the following checks while the unit is still on the machine. Install a 0-3000 PSI pressure gauge in a pipe tee in the line near the pressure port.

1. Energize the "raise switch" until hydraulic ram is fully extended and up against the stop, relief valve should be blowing and the pressure gauge should read 2600 PSI, which is factory set.
2. Energize both the "raise switch" and the "lower switch". The solenoid-operated release valve should be open and allowing the pump's flow to circulate through the sleeve filter and release valve and back to reservoir. The pressure gauge should read no more than 500 PSI at this time.

If these functional checks reveal differences, see "Trouble Shooting Chart" for correction.

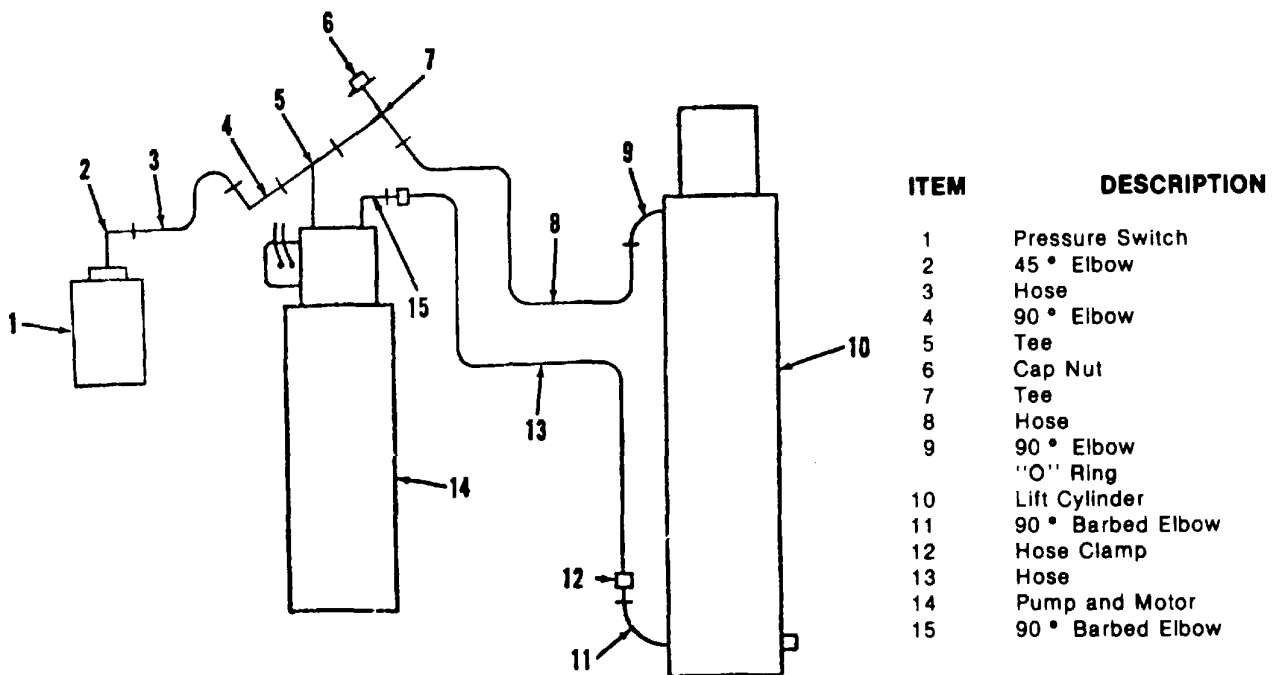

Figure 22 - Hydraulic Diagram

## HYDRAULIC SYSTEM

## TROUBLESHOOTING CHART

## Before Using This Chart - Read The Instructions Under Trouble-Shooting

Trouble	Cause	Remedy
External Leakage	Loose fittings Damaged or broken	Tighten Examine and replace if necessary.
Pump does not start	Pump binding or jammed pump gear  Improper electrical connection	Replace pump  Check electrical wiring
Pump and motor operates smoothly but "raises" load slowly or not at all	Weak battery Low voltage  Load too heavy  Low oil level  Relief valve leaking or setting too low.  Clogged inlet strainer  Solenoid operated release valve open  Check valve gasket leaking  Worn pump Check valve leaking	Check battery - charge  Lighten load  Eliminate leakage Replenish oil supply  Clean relief valve seat. Replace ball and spring when ball is nicked or damaged. Set relief valve at 2600 P.S.I.  Replace  Remove, dunk pump end in solvent and blow out cavity with air hose. Replace when necessary  Remove clean seat. Replace gasket when deformed or damaged  Replace pump
Pump will not "hold" load	Check valve leaking	Remove, check valve seat, replace ball and spring when separated. Replace gasket when damaged.
Pump will not hold load	Solenoid-operated release valve leaking  Auxiliary release valve leaking	Remove, clean pump end with solvent and blow out cavity with compressed air. Replace when necessary  Remove clean seat, check ball, replace ball when scored. Screw should hold ball snug against seat.
Pump will not release load	Solenoid-operated release valve sticking in closed position or wiring clips not making contact with solenoid terminals	Wire clips can be pushed in too far Push lugs all the way in. then pull back on soldered end until it snaps in place Replace valve when necessary.
Pump lowers load slowly	Clogged filter element	Remove, clean in solvent blow out with air hose from inside out Replace when damaged

HYDRAULIC SYSTEM

TROUBLESHOOTING CHART

Before Using This Chart - Read The Instructions Under Trouble-Shooting

Trouble	Cause	Remedy
Jerky movement of load	Solenoid-operated release valve not fully opened	Remove, clean pump end in solvent and blow out cavity with air hose Replace solenoid valve when this does not correct.
	Bind In rams or linkage, air in system, low oil level, defective oil seal	Check load axle for damage or bind Lubricate load axles, check oil level Add proper grade hydraulic oil to within 1/8" of filler port opening  Replace packing in ram when cylinders leak or oil by-passes piston packing.  Replace pump oil seal



## BATTERY CARE

### BATTERY CARE

The care and maintenance of storage batteries is of utmost importance if maximum battery life and most efficient truck operation are to be obtained. Periodic inspection and service will increase the life of batteries. We would suggest that special attention be given to the following rules:

### CLEANING

- a. Keep batteries clean at all times. Cleaning will prevent corrosion, current leakage and grounds
- b. Tighten all vent plugs, wash battery with water, use an air hose to dry and clean with a cloth
- c. It may be necessary to use a sodium bicarbonate solution if water alone will not clean top of battery, then wash with water and a brush
- d. Dry with an air hose

### ADDING WATER

- a. Add water at regular intervals. Enough water should be added to bring the electrolyte about 1/2" above the plates This is a simple matter with the use of an automatic cell; filler, not available from Yale, which shows a light when the proper level has been reached.
- b. Water should always be added before charging to insure thorough mixing with acid when gassing occurs near the end of charging period. Use distilled water or have your water supply analyzed.

### CHARGING

- a. Charge battery correctly. It is important that all batteries be charged according to the manufacturers instructions. Today's charging equipment is fully automatic and should be checked periodically. Never attempt to operate a truck with a fully discharged battery as this will damage the contractors, motors and resistors.

- b. Never overcharge a battery as this will damage the battery plates. Give the battery an equalizing charge at least once a week. An equalizing charge is an extra three to four hour charge at a low rate given after a normal charge, to make sure all cells are in fully charged condition.

- c. Regular battery readings should be taken with a hydrometer or voltmeter and a written record kept Readings should never be taken directly after water has been added.

### RECORDS

- a. Keep accurate battery records. Case histories on batteries should be kept or record. Refer to Battery Record form, copies can be made for own use. Specific gravity and voltage of each cell should be checked and recorded at least once a month.
- b. This inspection , should be made after an equalizing charge. Records of all battery maintenance should be made and filed to enable the maintenance crew to note which batteries are being abused or wearing out.
- c. Repairs should be made immediately otherwise tie remainder of battery may become damaged.
- d. When the specific gravity of a battery is above 1200 the truck is usually good for another four hours of operation It is a good idea to take battery reading every four hours.
- e. Changing a battery before it is completely discharged will save many hours of down time due to repairs. Do not follow the practice of running the battery down lower than 1150 before recharging.

**Important:** The charging and repair of batteries should be under direct charge of a competent person. No unauthorized person should be allowed to service batteries.

**Supplemental Operating, Maintenance  
and Repair Parts Instructions  
For  
TRUCK, PALLET-TYPE, 12-VOLT  
ELECTRIC-DRIVEN, SOLID RUBBER  
TIRES, 4, 000 LB CAPACITY  
(YALE MODEL MP040C2M2742EE)  
(NSN 3930-01-089-1429)**

SECTION		<i>Paragraph</i>	<i>Page</i>
	I. GENERAL		
	Purpose .....	1-1	89
	Scope .....	1-2	89
	Description .....	1-3	89
	Operational concept .....	1-4	89
	Procurement status .....	1-5	89
	Equipment publications .....	1-6	89
	Personnel and training .....	1-7	89
	Logistics assistance .....	1-8	89
	Warranty .....	1-9	89
	II. MAINTENANCE		
	Maintenance concept } Maintenance allocation chart (MAC) } Maintenance expenditure limits (MEL) }	2-1	91
	Reliability and maintainability .....	2-2	91
	Modifications .....	2-3	91
	Equipment improvement recommendations (EIR) .....	2-4	91
	Shipment and storage .....	2-5	91
	Destruction to deny enemy use .....	2-6	91
	Basic issue items list (BIIL) .....	2-7	91
	Special tools and equipment .....	2-8	91
	Preventive maintenance checks and services (PMCS) .....	2-9	91
	Maintenance and operating supply list .....	2-10	92
	Maintenance forms and records.....	2-11	92
	III. REPAIR PARTS SUPPLY		
	General .....	3-1	93
	Prescribed load list (PLL) .....	3-2	93
APPENDIX	A. SPECIAL NOTES AND CORRECTIONS .....		A-1
	B. WARRANTY .....		B-1
	C. MAC .....		C-1
	D. MEL CHART.....		D-1
	E. PREVENTIVE MAINTENANCE CHECKS AND SERVICES (PMCS).....		E-1
	F. LUBRICATION CHART.....		F-1
	G. MAINTENANCE AND OPERATING SUPPLY LIST .....		G-1
	H. ASL/PLL .....		H-1



## SECTION I

## GENERAL

**1-1. Purpose**

This Supplemental, operating, maintenance, and repair parts instructions (SOMARPI) supplements the manufacturer's equipment publication with additional maintenance and repair parts information needed for US Army units.

**1-2. Scope**

This publication applies to US Army units, organizations and activities that use and/or support the walkie-type, 4000-lb capacity, electric-powered pallet truck NSN 3930-01-089-1429, (Yale Industrial Truck Model MP040C2M2742EE).

**1-3. Description**

The truck is electrically powered, has two speeds, forward and reverse, and is capable of lifting (4 inches) and moving (1.5 mph (low), 2.5 mph (high)) up to 4000 pounds of palletized cargo. All spark-generating components are sealed, which renders the truck sparkproof. The truck is designed to be controlled by the operator who, while walking, steers with the control handle that extends from the rear of the truck.

**1-4. Operational Concept**

The truck is intended to handle heavy skid or storage platforms in the 4,000-lb. capacity range. Also, this truck facilitates short haul, manual, warehousing, and storage activities.

**1-5. Procurement Status**

Deleted.

**1-6. Equipment Publications**

Additional copies of this manual may be ordered through normal publications channels.

**1-7. Personnel and Training**

a. MOS Requirements. Qualitative and quantitative personnel requirements information (QQPRI) will be disseminated IAW AR 611-1. The following MOS's can operate and maintain the end item:

- (1) Operator. 62F.
- (2) Organizational maintenance. 63S.
- (3) Direct and general support maintenance. 63W.

## b. Training.

(1) New equipment training team (NETT). New equipment training teams are available to major field commands. Request for NETT's should be forwarded to Commander, US Army Tank-Automotive Command, AITN: DRSTA-MLT, Warren, MI 48090. Training teams should be requested only when trained personnel are not available in the command to operate and/or maintain the truck.

(2) New materiel introductory teams (NMIT). Major field commands requiring briefings to command staff and users should forward their requests to Commander, US Army Tank-Automotive Command, ATTN: DRSTA-MLT, Warren, MI 48090. Receiving commands are responsible for the itinerary of NMIT's.

**1-8. Logistics Assistance (AR 700-4)**

US Army Tank-Automotive Command's field maintenance technicians stationed at CONUS and OCONUS installations are available to furnish on-site training and/or technical assistance. Assistance can be obtained by contacting the appropriate logistics assistance office (LAO) listed in appendix B, AR 700-4.

**1-9. Warranty**

The warranty for this pallet truck is 180 days or 1000 hours, whichever occurs first, following the date of acceptance by the government. See appendix B for warranty claim guidelines (IAW TM 38-750).

**SECTION II**

**MAINTENANCE**

**2-1. Maintenance Concept**

The truck will not require special or new maintenance considerations. Maintenance operations can be accomplished within the current maintenance support concept for materiel handling equipment.

*a. Nature and Extent of Maintenance*

(1) *Maintenance allocation chart (MAC).* Maintenance will be performed as necessary by the category indicated in the MAC (App. C) to retain and/or restore serviceability. Units may exceed their authorized scope and function in the MAC when approved by their commander.

(2) *Operator maintenance.* Operator maintenance is limited to daily preventive maintenance checks and services (App. E).

(3) *Organizational maintenance.* Organizational maintenance consists of scheduled preventive maintenance services, minor repairs and adjustments.

(4) *Direct support maintenance.* Direct support maintenance consists of repairs on site and for return to the user of the end item/assemblies which can be maintained efficiently with a minimum of tools and test equipment.

(5) *General support maintenance.* General support maintenance will overhaul and repair for return to stock items designated by the area support commander.

(6) *Depot maintenance.* There is no scheduled depot maintenance on the truck.

*b. Maintenance Expenditure Limit.* The maintenance expenditure limit is based on a life expectancy of 18 years. Limits on repair are based upon 50% replacement cost for the first 12 years and 30% for the last six years of the truck (App. D).

**2-2. Reliability and Maintainability (RAM)**

Reliability and maintainability will be assessed through the field evaluation of current users. Specific numerical RAM requirements or objectives are not established.

**2-3. Modifications**

Modifications will be accomplished by the end item manufacturer after MERADCOM acceptance and TACOM approval.

**2-4. Equipment Improvement Recommendations (EIR)**

Equipment improvement recommendations will be submitted IAW TM 38-750.

**2-5. Shipment and Storage**

*a. Shipment and Storage.* Refer to TB 740-97-2 for procedures covering preservation of equipment for shipment. General procedures for shipment are found in FM 55-15, with more specific information in TM 55-2200-001-12 for rail and TM 55-450 series for air transport.

*b. Administrative Storage.* Refer to TM 740-90-1 for instructions covering administrative storage of equipment.

*c. Weight Classification.* The weight classification of the end item is 1, 687 pounds.

**2-6. Destruction To Deny Enemy Use**

Refer to TM 750-244-3 for instructions governing destruction of equipment to prevent enemy use.

**2-7. Basic Issue Items List (BIIL)**

SMR code	National Stock number	Description Ref. No. and MFG code	Usable on code	Unit of Qty measure	Auth
<b>NOTE</b>					
The following items are overpacked with the Yale 4000-lb. Model MP040C2M2742EE					
	7520-00-559-9618	Case, Cotton Duck: MIL-B-11743		ea.	1
	7510-00-889-3494	Log Book Binder: MIL-B-43064		ea.	1
<b>NOTE</b>					
Both will be replaced in later models by:					
	7530-01-065-01661	Equipment Record Folder		ea	1

**2-8. Special Tools and Equipment**

Special tools and equipment are not required for the truck.

**2-9. Preventive Maintenance Checks and Services**

See appendix E.

**2-10. Maintenance and Operating Supply List**

See appendix G for a list of maintenance and operating supplies required for initial operation.

**2-11. Maintenance Forms and Records**

Operational, maintenance and historical forms/records will be IAW the current TM 38-750.

## SECTION III

## REPAIR PARTS SUPPLY

**3-1. General**

a. The basic policies and procedures in AR 710-2 and AR 725-50 are generally applicable to repair parts management for material handling equipment (MHE) items.

b. Manufacturer's parts manuals are furnished with manufacturer's part list instead of Department of the Army repair parts and special tool list (RPSTL).

c. National stock numbers (NSNs) are initially assigned only to PLL/ASL parts and major assemblies; i.e., traction motor, pump motor, etc. Additional NSN's are assigned by the supply support activities as demands warrant.

d. Automated processing (AUTODIN) of Federal supply code manufacturer (FSCM) part number requisitions, without edit for matching NSN's and exception data, is authorized.

e. Proper use of direct support system (DSS) project codes is essential. Weapon system designator codes on part requisitions are not required.

f. Repair parts are available from commercial sources for CONUS units and may be purchased locally IAW AR 710-2 and AR 735-110.

g. Initial prescribed load list (PLL) and authorized stockage list (ASL) will be distributed by the US Tank-Automotive Command (TACOM), DRSTA-FHM.

**3-2. Prescribed Load List/Authorized Stockage List (PLL/ASL)**

a. Prescribed Load List (PLL) (Appendix H). The PLL, is an estimated 15 days supply recommended for initial stockage at organizational maintenance. Management of PLL items will be governed by the provisions of AR 710-2 and local command procedures. A prepared list of PLL parts will be provided on OCONUS units before shipment of the end item. Selection of PLL parts for shipment to OCONUS units is based upon the receiving command's recommendations after their review of the TACOM prepared list. Organizations and activities in CONUS will establish PLL stocks through normal requisitioning process (App. H).

**NOTE**

Local purchase of repair parts is authorized  
IAW AR 710-2 and AR 735-110.

**APPENDIX A**  
**SPECIAL NOTES & CORRECTIONS**

---

**A-1/(A-2 blank)**

## APPENDIX B

## Warranty Guidelines

**1. Application of Warranty Period**

A warranty period of 180 days or 1000 hours applies to the pallet truck. After delivery to the Government, this warranty applies to truck and components furnished under contract DAAE07-79-C-6017.

**2. Support Activities**

Maintenance activities in support of organizational units are the responsible points of contact for the originator of warranty claims and the National Maintenance Point.

**3. Notification of SF Form 368**

CONUS and OCONUS Units must notify the National Maintenance Point (NMP) (US Army Tank-Automotive Command, ATTN: DRSTA-MVM, Warren, MI 48090) AUTOVON 786-7363, of SF Form 368, for warranty claims as indicated in paragraph 4a. *At that time, you will be instructed whether to repair or take your equipment to a local dealer.*

**NOTE**

In certain instances, the originating organization and the support activity are one and the same.

**4. General Information**

a. SF Form 368 (prepared in accordance with warranty claim actions in TM 38-750, 31 May 1981) will be used to submit warranty claim actions when the truck or components are defective and are covered by a manufacturer's warranty.

b. Before you take your equipment to a dealer for repair, check with your local procurement office to see if a funds commitment document is needed. Sometimes, even though the majority of the repairs are covered by the warranty, there may be a small charge for normal maintenance costs, i.e., oil filters, oil, etc. Further,

the cause of damage could be determined by the dealer to be directly related to "operator abuse." In that case, the Government may be obligated to pay for tear-down services even if the repairs are no longer desired or for the complete cost if repairs are to be completed by the dealer.

c. When the equipment is given to the dealer for repairs, find out how long the work will take, the extent of the problem if possible and the charges, if any, which may be involved. Leave the name and telephone number of the person to be contacted for pick-up of the equipment and specifically state that he should be called as soon as the repairs are finished. In addition, state he should be telephoned if unexpected problems, costs and/or delays are encountered. Get the name and telephone number of the service manager, for any required follow-up purposes.

d. When you arrive to pick-up your equipment after completion of services, make certain that you know what repairs were performed and/or parts replaced. This is required for overall problems trend evaluation by the NMP and must be identified upon completion of warranty services.

e. Telephone the NMP, AUTOVON 786-7363, if any of the following problems arise:

(1) Your equipment requires repairs and you cannot obtain these services using the procedures listed above.

(2) The length of time required for repairs may seriously hamper your mission or if the dealer's overall response to your requirements is not satisfactory.

(3) You have any questions regarding warranty procedures either in general or about a specific job. Do not wait until problems become critical.

f. *Do not attempt to conduct negotiations regarding a breach of warranty.* This is a function of the contracting officer, through the NMP at TACOM.

## APPENDIX C

## MAINTENANCE ALLOCATION CHART

## Section I. INTRODUCTION

**1. General**

a. This section provides a general explanation of all maintenance and repair functions authorized at various maintenance levels.

b. Section II designates overall responsibility for the performance of maintenance functions on the identified end item or component and the work measurement time required to perform the functions by the designated maintenance level. The implementation of the maintenance functions upon the end item or component will be consistent with the assigned maintenance functions.

c. Section III lists the tools and the test equipment required for each maintenance function as referenced from section II.

**2. Explanation of Columns in Section II**

a. *Column 1. Group Number.* Column 1 lists group numbers to identify related components, assemblies, subassemblies, and modules with their next higher assembly. The applicable groups are listed in the MAC is disassembly sequence beginning with the first group removed.

b. *Column 2. Component/Assembly.* This column contains the noun names of components assemblies, subassemblies and modules for which maintenance is authorized.

c. *Column 3, Maintenance Functions.* This column list the functions to be performed on the item listed in column 2. The maintenance functions are defined as follows:

(1) *Inspect.* To determine serviceability of an item by comparing its physical, mechanical, and/or electrical characteristics with established standards through examination.

(2) *Test.* To verify serviceability and detect incipient failure by measuring the mechanical or electrical characteristics of an item and comparing those characteristics with prescribed standards.

(3) *Service.* Operations required periodically to keep an item in proper operating condition, i.e., clean (decontaminate), preserve, drain, paint, or replenish fuel, lubricants, hydraulic fluids, or compressed air supplies.

(4) *Align.* To adjust specified variable elements of an item to bring about optimum or desired performance.

(5) *Calibrate.* To determine and cause corrections to be made or to be adjusted on instruments or test measuring and diagnostic equipment used in precision measurement. Consists of comparison of two instruments, one of which is a certified standard of known accuracy, to detect and adjust any discrepancy in the accuracy of the instrument being compared.

(6) *Install.* The act of emplacing, seating, or fixing into position an item, part or docule (component or assembly) in a manner to allow the proper functioning of an equipment or system.

(7) *Replace.* The act of substituting a serviceable like type part, subassembly, or module - (component or Assembly) for an unserviceable counterpart.

(8) *Repair.* The application of maintenance services (inspect, test, service, adjust, align or calibrate) or other maintenance actions (welding, grinding, riveting, straightening) to an item by correcting specific damage, malfunction, or failure in a part, subassembly, module (component or assembly).

(9) *Overhaul.* That maintenance effort (service/action) necessary to restore an item to completely serviceable/operational condition as prescribed by maintenance standards (i.e., DMWR) in appropriate technical publications. Overhaul is normally the highest degree of maintenance performed by the Army. Overhaul does not normally return an item to a like new condition.

d. *Column 4. Maintenance Category.* This column is made up of sub-columns for each category of maintenance. Work time figures are listed in these sub-columns for the lowest level of maintenance authorized to perform the function listed in Column 3. These figures indicate the average active time required to perform the maintenance function at the indicated category of maintenance under typical field operation conditions.

*Explanation of maintenance category in section II, MAC chart.*

C - Operator/Crew

O - Organizational

F - Direct Support

H - General Support

D - Depot

e. *Column 5. Tools and Equipment.* This column is provided for referencing by code, the common tool sets (not individual tools) special tools, test and support equipment required to perform the designated function.

**3. Explanation of Column in Section III**

a. *Column 1. Reference Code.* This column consists of an Arabic number listed in sequence from section II, column 5. The number references the common tool sets, special tools and test equipment.

b. *Column 2. Maintenance Level.* This column shows the lowest category of maintenance authorized to use the special tools or test equipment.

c. *Column 3. Nomenclature.* This column lists the name or identification of the common tool sets, special tools or test equipment.

d. *Column 4. National/NATO Stock No. (NSN).* This column is provided for the NSN of common tool sets, special tools and test equipment listed in the nomenclature column.

**Section II. MAINTENANCE ALLOCATION CHART FOR TRUCK, LOW LIFT, PALLET, 4000-LB CAPACITY**

*Assignment of Maintenance Functions*

(1) GROUP NUMBER	(2) COMPONENT ASSEMBLY	(3) MAINTENANCE FUNCTION	(4) MAINTENANCE CATEGORY					(5) TOOLS AND EQUIPMENT
			C	O	F	H	D	
06	ELECTRIC SYSTEM							
0606	Safety Controls	Test		0.2				
	Hydraulic Pressure Switches	Replace		0.9				
0608	Miscellaneous Items: Connector, mounting Half	Inspect	0.1					
		Replace		0.8				
0611	Horn							
	Button horn assy	Replace		0.1				
		Repair		0.4				
	Horn assembly	Test	0.2					
		Replace		0.6				
	Horn wiring	Inspect		0.4				
		Replace		0.4				
0612	Batteries							
	Receptacle, Charging	Inspect		0.1				
		Replace		0.9				
		Repair			1.0			
	Battery, Storage	Inspect	0.2					
		Test		0.4				2
		Service		8.0				2
		Replace		0.6				
		Overhaul					19.0	2
	Cable, battery	Inspect		0.1				
		Replace		0.8				
	Hull or Chassis Wiring Harness, wiring	Inspect		0.3				1
		Replace			2.5			
		Repair			0.5			1
	Covers (battery compartment)	Inspect		0.1				
		Replace		0.1				
1005	Caster Front Axle							
	Forks	Inspect		0.1				
	Roller Assembly	Replace		0.2				
	Bearings	Inspect		0.2				
		Repair			3.0			
	Tires, Solid	Inspect		0.2				
11	REAR AXLE	Replace				1.7		3
1100	Rear Axle assembly driving unit	Inspect	0.2					
		Service		0.4				
		Replace			6.0			
		Repair			3.0			
		Overhaul				20.0		
			<b>C-2</b>					



Assignment of Maintenance Functions - Continued

(1) GROUP NUMBER	(2) COMPONENT ASSEMBLY	(3) MAINTENANCE FUNCTION	(4) MAINTENANCE CATEGORY					(5) TOOLS AND EQUIPMENT
			C	O	F	H	D	
1102	Differential Bearing Gears Seals, Oil Gasket	Inspect Service Replace Repair Overhaul			5.0 4.0 6.0 6.0 15.0			
1104	Steering and Leaning Mechanism Spring Return Assembly Handle Assembly Steering Turntable	Inspect Adjust Replace Inspect Replace		0.2   0.3	0.4 0.4 6.0			
13	WHEEL							
1311	Wheel Assembly Bearing rear wheel	Inspect Service Adjust Replace		0.9 0.3 0.2 1.5				
	Wheel Assembly	Inspect Replace		0.4 1.5				
15	FRAME							
1501	Platform and Frame Assembly Carriage Assembly	Inspect Replace Repair			0.6 1.5 2.5			
18	BODY, CAB, HOOD, AND HULL							
1801	Body Shroud, drive motor	Replace Repair		1.2 1.8				
1808	Carrying Case Case Manuals	Replace Repair		0.3 0.7				
22	MISCELLANEOUS BODY Chassis or Hull and Accessory Items				1.5 0.6 2.0			
2210	Data Plates Plates Data	Inspect Replace	0.1	0.5		4.2		
24	HYDRAULIC LIFT COMPONENTS							
2400	Hydraulic Pump Pump, rotary, power driven, hydraulic	Inspect Replace Repair		0.6	1.5 2.5			
2402	Hydraulic Control Valve Valve, directional control	Inspect Replace Repair		0.3	1.6 2.0			
2405	Hydraulic Cylinders Cylinder assembly, Lift	Inspect Replace Repair		0.3 1.8	1.0			
2406	Hydraulic Lines and Fittings Cap, oil breather Filter element	Inspect Replace Inspect Replace	0.1 0.1	0.1 0.4				
			<b>C-3</b>					

Assignment of Maintenance Functions - Continued

(1) GROUP NUMBER	(2) COMPONENT ASSEMBLY	(3) MAINTENANCE FUNCTION	(4) MAINTENANCE CATEGORY					(5) TOOLS AND EQUIPMENT
			C	O	F	H	D	
40	Hoses assembly, rubber	Inspect	0.1					4
		Replace		0.6				4
4000	Tank, oil	Repair		0.4				
		Inspect	0.1					
4001	ELECTRIC MOTORS Motor Assembly Drive	Service	0.2					
		Replace			1.0			
4003	Brush Holders Brush, electrical contact	Inspect		2.0				
		Replace			2.5			
4005	Holder, electrical, contact, brush Endbell	Inspect			2.0			
		Replace			1.5			
4006	Frame Supports and Housing Bearing, ball annular, drive motors	Inspect			2.0			
		Replace			1.5			
4007	Starting and Protective Devices Circuit Breaker (Drive motor)	Inspect			3.5			
		Replace			4.0			
4008	Drive Components Adapter Assembly Gear Reduction	Replace			1.0			
		Inspect		0.4				
4009	Brakes Brake assembly	Service		0.7				
		Replace			1.0			
4010	Cover manual Brake release Control Panels Housing, Cubicles Control Head Assembly	Repair			1.0			
		Adjust			1.8			
4010	Handle (Grip) Contact, Electrical	Replace		.05				
		Inspect			0.5			
4010	Contact, Electrical	Replace			1.0			
		Repair			1.5			
4010	Contactor, rwd & rev	Replace		.05				
		Inspect		0.2				
4010	Contactor, rwd & rev	Adjust		0.1				
		Replace		0.2				
4010	Contactor, rwd & rev	Inspect		0.2				
		Replace			0.8			1
4010	Contactor, rwd & rev	Repair			0.4			

Assignment of Maintenance Functions - Continued

(1) GROUP NUMBER	(2) COMPONENT ASSEMBLY	(3) MAINTENANCE FUNCTION	(4) MAINTENANCE CATEGORY					(5) TOOLS AND EQUIPMENT
			C	O	F	H	D	
4011	Contact, electrical	Inspect		0.2				
		Adjust		0.1				
		Replace		0.2				
	Contactor, Hydraulic Pump	Inspect		0.2				
		Replace			0.8			
		Repair			0.4			
	Contact, electrical	Inspect		0.2				
		Adjust		0.1				
		Replace		0.2				
	Contactor, power	Inspect		0.2				
		Replace				0.8		
		Repair				0.4		
	Contact, electrical	Inspect		0.2				
		Adjust		0.1				
Replace			0.2					
Fuse & Circuit Breaker	Fuse, cartridge	Test		0.3			1	
		Replace		0.2				
		Inspect		0.2				
Fuse holder	Fuse holder	Inspect		0.2				
		Replace			0.4			
		Inspect		0.2				
Link, fuse	Link, fuse	Inspect		0.2				
		Replace			0.2			
		Inspect		0.2				
4012	Switches, Contractors and Relays Switch, Directional Control	Inspect		0.3			1	
		Replace			0.6			
		Repair			0.3			
4014	Fixed Resistor	Test			0.5			
4015	Relay, Thermal	Replace			0.8			
		Inspect		0.3				
		Test			0.2			
4019	Strap, Static Drag	Replace			0.3			
		Inspect		0.2				
42	ELECTRICAL EQUIPMENT NOT CONTAINED IN OTHERFUNCTION GROUPS	Replace		0.3				
		Replace						
4216	Miscellaneous wiring and fittings	Replace			0.8		1	
		Repair			1.0		1	

Section III. TOOL AND TEST EQUIPMENT REQUIREMENTS

(1) Reference Code	(2) Maintenance Level	(3) Nomenclature	(4) NSN NATO Stock Number
1	O	Multimeter	6625-00-553-0142
2	O	Hydrometer	6630-00-171-5126
3	H	Hydraulic press	3444-00-449-7295
4	O	Hydraulic pressure gage	6685-00-998-8060
5	F	Armature tester	6625-00-238-1460
6	F	Ohmmeter	6625-00-548-0127
7	F	Armature tester	6625-00-238-1459
8	H	Oscilloscope	6625-00-127-0079

APPENDIX D

MAINTENANCE EXPENDITURE LIMITS

NSN 1	Item Identification 2	Production year 3	Years of life expectancy 4	Repair Limitations	
				50% 5	30% 6
3930-01-089-1429	Truck, Pallet, Forklift, Electric-Powered 4000-lb. Capacity, Army Model MPO40C2M2742 EE	80	18	1992	1998

D-1/(D-2 blank)

## APPENDIX E

## PREVENTIVE MAINTENANCE CHECKS AND SERVICES

- 1 Do your before (B) preventive maintenance just before you operate the vehicle. Pay attention to the cautions and warnings.
- 2 During checks and services (D) of preventive maintenance will be performed while the equipment and/or its components systems are in operation.
- 3 Do your after (A) preventive maintenance right after operating the vehicle. Pay attention to the cautions and warnings.
- 4 Do your weekly (W) preventive maintenance weekly.
- 5 Do your monthly (M) preventive maintenance monthly.
- 6 If something doesn't work, troubleshoot it with the instructions in your commercial manual, or notify your supervisor.
- 7 Always do your preventive maintenance in the same order so it gets to be a habit. Once you've had some practice, you'll spot anything wrong in a hurry.
- 8 If anything looks wrong and you can't fix it, write it on your DA Form 2404. If you find something seriously wrong, report it to organizational maintenance immediately.
- 9 When you do your preventive maintenance, take along the tools you will need to make all the checks. Take along a rag, you'll always need at least one.

**WARNING**

Dry cleaning solvent, used to clean parts, is potentially dangerous to personnel and property. DO NOT use near open flame or excessive heat. Flash point of this solvent is 138°F.

- A. *Keep it clean.* Dirt, grease, oil and debris only get in the way and may cover up a serious problem. Clean as you work and as needed. Use dry cleaning solvent (SD-2) on all metal surfaces. Use soap and water when you clean rubber or plastic material.
- B. *Bolts, nuts and screws.* Check them all for obvious looseness, missing, bent or broken condition. You can't try them all with a tool, of course, but look for chipped paint, bare metal or rust around bolt heads. If you find one you think is loose, tighten it or report it to organizational maintenance if you cannot tighten it.

- C. *Welds.* Look for loose or chipped paint, rust or gaps where parts are welded together. If you find a bad weld, report it to organizational maintenance.
- D. Electric wires and connectors. Look for cracked or broken insulation, bare wires, and loose or broken connectors. Tighten loose connectors and make sure the wires are in good shape.
- E. Hoses and fluid lines. Look for wear, damage, and leaks and make sure clamps and fittings are tight. Wet spots show leaks, of course, but a stain around a fitting or connector can mean a leak. If a leak comes from a loose fitting or connector, tighten it. If something is broken or worn out, report it to Organizational maintenance.
10. It is necessary for you to know how fluid leakage affects the status of your vehicle. The following are definitions of the types/classes of leakage you need to know to be able to determine the status of your vehicle. Learn, then be familiar with them and remember-when in doubt, notify your supervisor!

*Leakage Definitions for Crew/Operator PMCS*

- Class I - Seepage of fluid (as indicated by wetness or discoloration) not great enough to form drops.
- Class II - Leakage of fluid great enough to form drops, but not enough to cause the drops to drip from the item being checked/inspected.
- Class III - Leakage of fluid great enough to form drops that fall from the item being checked/inspected.

**CAUTION**

Equipment operation is allowable with minor leakages (Class I or II). Of course, consideration must be given to the fluid capacity in the item/system being checked/inspected. When in doubt, notify your supervisor.

When operating with Class I or II leaks, continue to check fluid levels as required in the PMCS.

Class III leaks should be reported to your supervisor or to organizational maintenance.

**OPERATOR/CREW PREVENTIVE MAINTENANCE CHECKS AND SERVICES**  
**B - BEFORE      D - DURING      A - AFTER      W - WEEKLY      M - MONTHLY**

ITEM NO	INTERVAL					ITEM TO BE INSPECTED PROCEDURE:CHECK FOR AND HAVE REPAIRED, FILLED, OR ADJUSTED AS NEEDED	EQUIPMENT IS NOT READY/AVAILABLE IF:
	B	D	A	W	M		
1	•					<p>IMPORTANT: <i>Perform weekly as well as before operations PMCS if:</i></p> <p>1. You are the assigned operator and have not operated the item since the last weekly.</p> <p>2. You are operating the item for the first time.</p> <p>EXTERIOR OF VEHICLE Check for leaks or appearance of leaks.</p>	Class m leaks of any hydraulic oil leaks.
2	•					<p>HYDRAULIC RESERVOIR Check reservoir oil level, add oil if necessary, oil should run out slightly when pallet is lowered and all cylinders retracted.</p>	
3	•					<p>TIRES Check tires for wear, cracks, gouges and chunking.</p>	Chunking, gouging or obvious wear which would cause unsafe operating conditions.
4		•				<p>HORN Check horn by pressing button.</p>	
5		•				<p>BRAKES Check that service brake pressure stops truck.</p>	Service brake won't stop truck.
6		•				<p>STEERING Check that truck steers free and easy.</p>	
7		•				<p>HYDRAULIC LIFT Check that lifting and lowering pallet is smooth in lift linkage.</p>	Lifting or lowering is jerky or uncontrollable.
8				•		<p>BATTERY</p> <p>a. Check battery for cracks, keep clean at all times. Add distilled water to bring the electrolyte about 1/2" above the plates.</p> <p>b. Tighten all vent plugs.</p> <p>c. Give the battery an equalizing charge.</p>	

ORGANIZATIONAL PREVENTIVE MAINTENANCE CHECKS AND SERVICES

Q - QUARTERLY

S - SEMIANNUALLY

A - ANNUALLY

B - BIENNIALLY

M. - MONTHLY

W - WEEKLY

ITEM NO.	INTERVAL						ITEM TO BE INSPECTED PROCEDURE: CHECK FOR AND HAVE REPAIRED, FILLED, OR ADJUSTED AS NEEDED PERFORM ALL OPERATOR PMCS FIRST
	Q	S	A	B	M	W	
1							<p><b>NOTE</b></p> <p>Perform operator/crew PMCS prior to or in conjunction with organizational PMCS if:</p> <p>a. There is a delay between the delay operation of the equipment and the organizational PMCS.</p> <p>b. Regular operator is not assisting participating.</p> <ul style="list-style-type: none"> <li>• MAJOR ASSEMBLY Check drive unit cover and retaining knobs, tighten if loose.</li> </ul>
2							<ul style="list-style-type: none"> <li>• MAJOR BOLT ON CONNECTIONS Control handle, drive axle units, and wheel bolts, should be checked and tightened if loose.</li> </ul>
3					•		<p>GEAR OIL</p> <p>Check gear oil level-remove drive unit level plugs, the oil should run out slightly. To add oil, leave oil level plug out while filling at breather plug in gear box top cover, until oil runs out level hole. Replace both plugs.</p>
4	•						<p>BRAKE SHOE PIVOT PINS</p> <p>Check and tighten if loose.</p>
5	•						<p><b>WARNING</b></p> <p>This truck has all spark generating components sealed, to render SPARKPROOF. When Electrical System and Electric Motors preventive maintenance checks are made, insure all gaskets, O-rings and grommets are properly installed to preserve the SPARKPROOF rating.</p> <p>HOSES, TUBES AND FITTINGS</p> <p>Inspect, for leaks, tighten or replace if necessary.</p>
6		•					<p>CHANGE GEAR OIL</p> <p>Drain system's oil and refill (refer to manufacturer's manual, page 39).</p>
7		•					<p>LOAD WHEEL BEARING</p> <p>Remove wheels, clean bearing and inspect for wear, repack (refer to manufacturer's manual, page 39).</p>
8		•					<p>ELECTRICAL SYSTEM</p> <p>Check for loose terminal and connectors, frayed insulation on wires and cables, and any damages or deformed component which would break the sparkproof seal.</p>
9		•					<p>HYDRAULIC RESERVOIR</p> <p>Check to make sure ram is fully extended. Remove filler plug through hole in truck frame. Oil level should be approximately 1/8" below inside diameter of cylinder.</p>
10			•				<p>ELECTRIC MOTORS</p> <p>Inspect the brushes; if they are worn within ¼" of the pig tail, they should be replaced.</p>

APPENDIX F  
LUBRICATION CHART

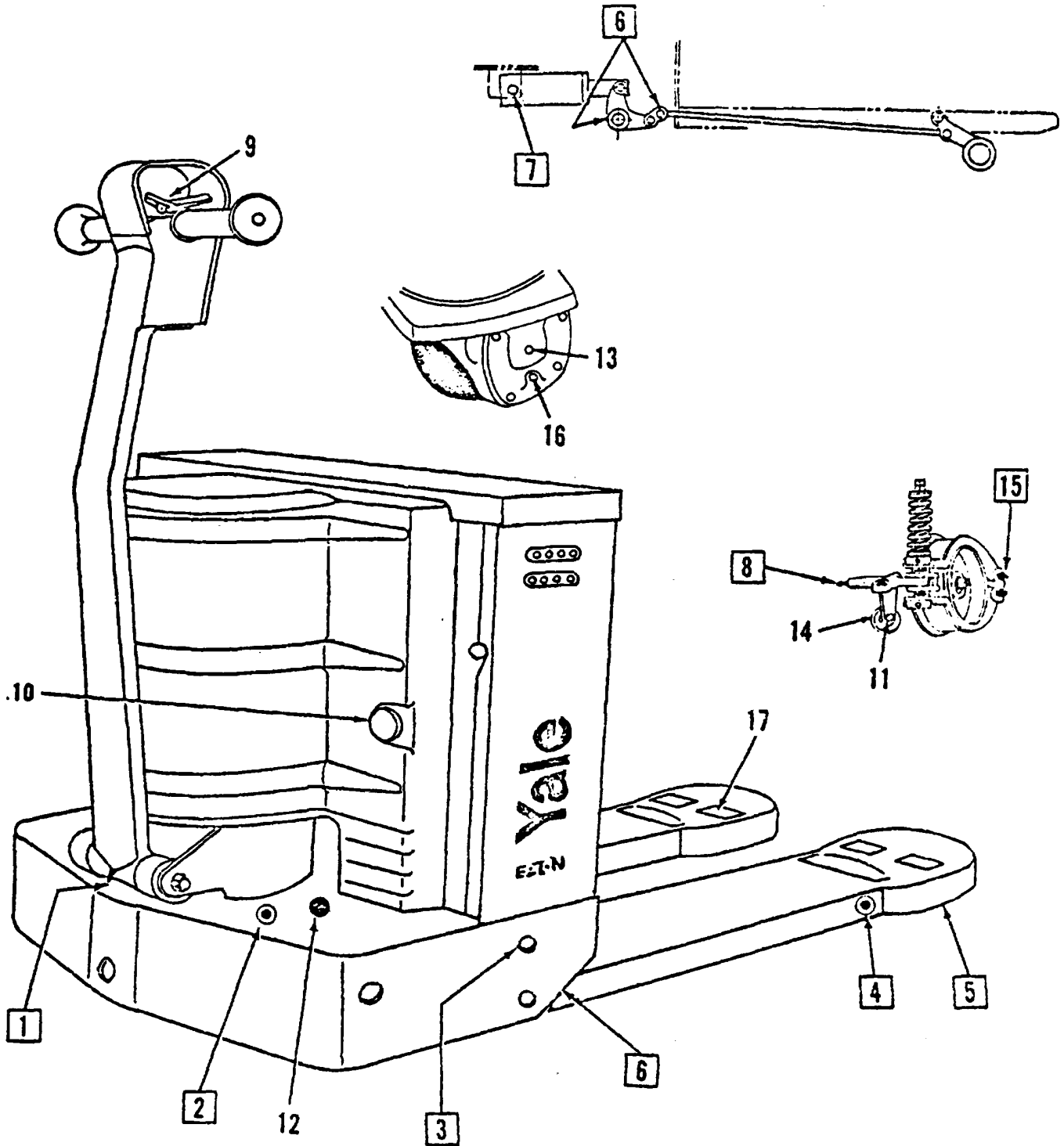

LUBRICATION CHART  
MP 40 LOW LIFT PALLET TRUCK  
Box number are grease points



SCHEDULE OF LUBRICATION  
MP 40 LOW LIFT PALLET TRUCK

**Every 200 Hours or Monthly** - Apply grease with Alemite high pressure gun.  
(Refer to Standard Lubricant List)  
Before Lubrication-Wipe fittings with a clean cloth.  
After Lubrication-Wipe excess grease from fittings.

Lubrication Points	No. of Points
1. Steer Handle Pivot Shaft .....	1
2. Drive Unit Ring Bearing-Both Sides .....	2
3. Adjusting Stud Pin-Both Sides .....	2
4. Load Wheel Link Pin-Both Sides of Both Pallet Forks .....	4
5. Load Wheel Axle-Elevate Pallet Forks .....	2
6A. Rocker Arm-Elevate Pallet Forks .....	7
6B. Adjusting Stud Pins-Thru Access Holes, Both Sides of Truck .....	2
7. Lift Cylinder Eccentric Pin-Near, Underside of Truck.....	1
8. Brake Cam-Remove Drive Unit Cover .....	1

**Every 200Hours or Monthly** - Apply SAE 20 or 30 oil with a spout can to all moving parts.

- 9. Travel Control Plate
- 10. Knobs-Remove Drive Unit Cover
- 11. Brake Cam Roller-Remove Drive Unit Cover

**Every 200 Hours or Monthly** - Check Oil Level-Refer to Standard Lubricant List)

- 12. Hydraulic Oil- Lift cylinder ram must be in extended position. Remove cylinder filler plug thru access hole in truck frame. Oil level should be 1/8" below inside diameter of lift cylinder.

**Every 400 Hours or Every 2 Months** - Refer to Standard Lubricant Lists)

- 13. Check Gear Oil Level-Remove drive unit plug, the oil should run out slightly. To add oil, leave oil level plug out while filling at breather plug in gear box top cover, until oil runs out level hole. Replace both plugs.
- 14. Apply Paratac Grease to Brake Cam and roller. Remove Drive Unit Cover.
- 15. Brake Shoe Pivot Pin-(2) Points-Remove Drive Unit Cover.  
Caution must be taken when greasing brake shoe pivot pins to allow excess grease to get on brake shoe linings which could cause brake failure. An extra precaution such as removing these lube fittings would be safe.

**Every 1200 Hours or Every 3 Months** - Refer to Standard Lubricant List)

- 16. Gear Oil-Drain drive unit and refill. Refer to item 13.
- 17. Load Wheel Bearings-Disassemble, clean and inspect bearings for wear or damage. Reassemble and grease.

**NOTE**

Do not expose Bearings or Hydraulic System unnecessarily to foreign particles. Use hands, tools and wipe rags free of all dirt and grit.

**NOTE**

The interval of time referred to in this schedule of lubrication is based on normal operating conditions. If the vehicle is operated in areas of high contamination such as dust, corrosive vapors, etc., the interval of time should be adjusted accordingly.

APPENDIX G

Maintenance and Operating Supplies List

Nomenclature: Truck, pallet powered, electric		Make: Yale		Model: MP040C2M2742 EE		
Mfr part No: Date MP040C2M2742 EE	NSN: 3930-01-089-1429	Serial No. range: N355602 N360986 to N361017 inclusive N363781 to N363903 inclusive		15 Sep 80		
Component application	Mfr part No. or Natl stock No.	Description	Qty req F/Initial OPN	Qty req F/8 hrs O	PN	Notes
Battery		Distilled Water	A/R			
Hydraulic Oil	9150-00-186-6668	MIL-L-2104C/MIL-L-2104B		A/R		
Lubrication	9150-00-190-0907	Multi Purpose Grease	A/R	A/R		Refer to
manufacturer's						publication,
Fittings		MIL-L-G010924				
pages 36						
Drive Unit	9150-00-035-5393	Gear Oil Lube, MIL-L-2105C 80W190	A/R	A/R		thru 40.

G-1/(G-2 blank)

APPENDIX H

PREScribed LOAD LIST/AUTHORIZED STOCKAGE LIST

ITEM: Truck, Pallet Lift, 4, 000 Lb., Electric, Model MP04OC2M2742 EE

CONTRACT: DAAE07-79-C-6017

CONTRACTOR: YALE INDUSTRIAL, Truck Div, Philadelphia, PA

QUANTITY: 188

PREVIOUS PROCUREMENTS: None

SMR	NSN	Part Number	FSCM	Part Description	U.M.	PLL 1-5	ASL 1-5	Unit Price
PAFZZ		10-727021	04426	Switch Mic	Ea	1	1	8.77
PAFZZ		<u>1067861-27</u>	<u>83299</u>	Fuse Link 200A	Ea	1	1	.85
PAFZZ	5920-00-256-5671	1067861-31	83299	Fuse Link 100A	Ea	1	1	.85
PAFZZ	5930-00-004-7746	7221523-00	83299	Switch	Ea	1	1	12.23
PAOZZ	5930-00-716-1484	5008631-00	83299	Switch Ign	Ea	1	1	3.35
PAFZZ		1356501-16	83299	Brush Set	Ea	1	1	17.63
PAFZZ	5905-00-418-3798	1180683DB	83299	Resistor	Ea	1	1	23.33
PAOZZ	5920-00-501-6528	ABC15	71400	Fuse 15 AMP	Ea	1	1	.20
PAOZZ	5920-00-501-6528	5009031-03	83299	Fuse 15 AMP	Ea	1	1	.20
PAFZZ	5977-00-710-2030	<u>MDL-2012AS</u>	<u>19728</u>	Brush Set	Ea	1	1	1.17
	5977-00-710-2030	0614994-00	83299					
PAFZZ		20400L29- 85L181-1.8	06668	Thermostat	Ea	2	2	10.89
PAFZZ	5330-00-006-8390	5152290-00	83299	Kit Lift Packing	Ea	1	1	31.54

H-1/(H-2 blank)

\* U.S. GOVERNMENT PRINTING OFFICE: 1981 - 554-002:1225

By Order of the Secretary of the Army:

Official:

E. C. MEYER  
*General, United States Army*  
*Chief of Staff*

ROBERT M. JOYCE  
*Brigadier General, United States Army*  
*The Adjutant General*

Distribution

To be distributed in accordance with DA Form 12-25A, organizational, direct support and general support maintenance requirements for truck, forklift, rough terrain.

## THE METRIC SYSTEM AND EQUIVALENTS

### LINEAR MEASURE

- 1 Centimeter = 10 Millimeters = 0.01 Meters = 0.3937 Inches
- 1 Meter = 100 Centimeters = 1,000 Millimeters = 39.37 Inches
- 1 Kilometer = 1,000 Meters = 0.621 Miles

### SQUARE MEASURE

- 1 Sq Centimeter = 100 Sq Millimeters = 0.155 Sq Inches
- 1 Sq Meter = 10,000 Sq Centimeters = 10.76 Sq Feet
- 1 Sq Kilometer = 1,000,000 Sq Meters = 0.386 Sq Miles

### CUBIC MEASURE

- 1 Cu Centimeter = 1,000 Cu Millimeters = 0.06 Cu Inches
- 1 Cu Meter = 1,000,000 Cu Centimeters = 35.31 Cu Feet

### LIQUID MEASURE

- 1 Milliliter = 0.001 Liters = 0.0338 Fluid Ounces
- 1 Liter = 1,000 Milliliters = 33.82 Fluid Ounces

### TEMPERATURE

- $5/9 (^{\circ}\text{F} - 32) = ^{\circ}\text{C}$
- 212 $^{\circ}$  Fahrenheit is equivalent to 100 $^{\circ}$  Celsius
- 90 $^{\circ}$  Fahrenheit is equivalent to 32.2 $^{\circ}$  Celsius
- 32 $^{\circ}$  Fahrenheit is equivalent to 0 $^{\circ}$  Celsius
- $9/5 \text{ C}^{\circ} + 32 = \text{F}^{\circ}$

### WEIGHTS

- 1 Gram = 0.001 Kilograms = 1,000 Milligrams = 0.035 Ounces
- 1 Kilogram = 1,000 Grams = 2.2 lb.
- 1 Metric Ton = 1,000 Kilograms = 1 Megagram = 1.1 Short Tons

### APPROXIMATE CONVERSION FACTORS

TO CHANGE	TO	MULTIPLY BY
Inches	Centimeters	2.540
Feet	Meters	0.305
Yards	Meters	0.914
Miles	Kilometers	1.609
Square Inches	Square Centimeters	6.451
Square Feet	Square Meters	0.093
Square Yards	Square Meters	0.836
Square Miles	Square Kilometers	2.590
Acres	Square Hectometers	0.405
Cubic Feet	Cubic Meters	0.028
Cubic Yards	Cubic Meters	0.765
Fluid Ounces	Milliliters	29.573
Pints	Liters	0.473
Quarts	Liters	0.946
Gallons	Liters	3.785
Ounces	Grams	28.349
Pounds	Kilograms	0.454
Short Tons	Metric Tons	0.907
Pound-Feet	Newton-Meters	1.356
Pounds Per Square Inch	Kilopascals	6.895
Miles Per Gallon	Kilometers Per Liter	0.425
Miles Per Hour	Kilometers Per Hour	1.609
TO CHANGE	TO	MULTIPLY BY
Centimeters	Inches	0.394
Meters	Feet	3.280
Meters	Yards	1.094
Kilometers	Miles	0.621
Square Centimeters	Square Inches	0.155
Square Meters	Square Feet	10.764
Square Meters	Square Yards	1.196
Square Kilometers	Square Miles	0.386
Square Hectometers	Acres	2.471
Cubic Meters	Cubic Feet	35.315
Cubic Meters	Cubic Yards	1.308
Milliliters	Fluid Ounces	0.034
Liters	Pints	2.113
Liters	Quarts	1.057
Liters	Gallons	0.264
Grams	Ounces	0.035
Kilograms	Pounds	2.205
Metric Tons	Short Tons	1.102
Newton-Meters	Pound-Feet	0.738
Kilopascals	Pounds Per Square Inch	0.145
Kilometers Per Liter	Miles Per Gallon	2.354
Kilometers Per Hour	Miles Per Hour	0.621

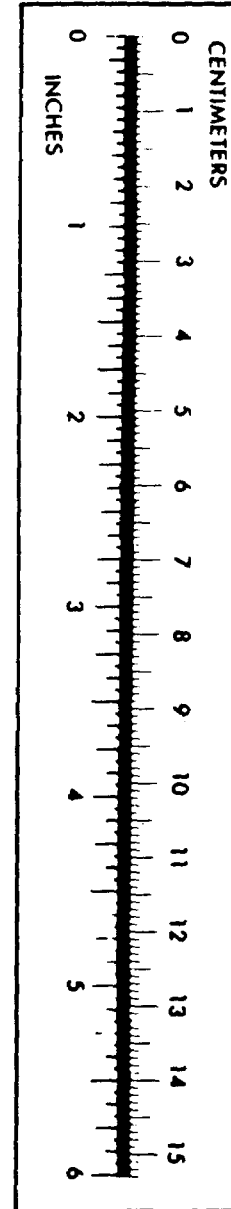

RECOMMENDED CHANGES TO EQUIPMENT TECHNICAL PUBLICATIONS



THEN... JOT DOWN THE DOPE ABOUT IT ON THIS FORM, CAREFULLY TEAR IT OUT, FOLD IT AND DROP IT IN THE MAIL!

**SOMETHING WRONG WITH THIS PUBLICATION?**

FROM: (PRINT YOUR UNIT'S COMPLETE ADDRESS)

DATE SENT

PUBLICATION NUMBER

PUBLICATION DATE

PUBLICATION TITLE

BE EXACT... PIN-POINT WHERE IT IS

PAGE NO.	PARA-GRAPH	FIGURE NO.	TABLE NO.
----------	------------	------------	-----------

IN THIS SPACE TELL WHAT IS WRONG AND WHAT SHOULD BE DONE ABOUT IT:

TEAR ALONG PERFORATED LINE

PRINTED NAME, GRADE OR TITLE, AND TELEPHONE NUMBER

SIGN HERE:

DA FORM 2028-2  
1 JUL 79

PREVIOUS EDITIONS ARE OBSOLETE.

P.S.—IF YOUR OUTFIT WANTS TO KNOW ABOUT YOUR RECOMMENDATION MAKE A CARBON COPY OF THIS AND GIVE IT TO YOUR HEADQUARTERS.

**PIN: 050173**